

Hall Effect Sensor IC with Thermal Lock Protection and Auto-restart Function

產品特色:

- 工作電壓範圍由 2.8 伏特至 20 伏特。
- 內建霍爾感應器。
- 內建穩壓器使工作穩定於不同電壓源。
- 最大輸出電流 500mA。
- 切換時，有較低的電流變換率。
- 有 SOT25,SIP-4L 及 SIP-5L 包裝。
- 內建風扇轉速產生器。
- 內建反向電壓保護二極體。
- 內建鎖定溫度保護裝置與自動啓動功能

功能描述:

WSH411 是一個整合霍爾感應器，互補性雙輸出以及轉速產生器在一起之整合型積體電路，它適用於轉速量測、位置定位及直流無刷式馬達上。WSH411 其內部包含溫度補償穩壓器、差動放大器、遲滯控制器、雙 open-collector 之輸出 NPN 電晶體可推動 500mA 以及一 open-collector 之轉速產生器其可推動 10mA，另外其內建反向電壓保護二極體可預防不小心之反向電壓之誤用。

WSH411 有另一重要之溫度特性優點，為其內建溫度相關之工作點，可使 WSH411 在不同之環境溫度下自動調整其工作點，並使其感應靈敏度隨溫度越高而越靈敏，如此造成本產品能工作於環境溫度 $-20^{\circ}\text{C} \sim 100^{\circ}\text{C}$ ，且工作範圍由 2.8V 至 20V。此一重要特性徹底改善在高溫下 IC 感應不良之問題。另一鎖定溫度保護與自動啓動功能，在高溫 135°C 時會把電源切除，以防止風扇因過熱而導致線圈燒毀並且於降溫後自動啓動，因此非常適合高轉速的風扇使用。可以取代一般的鎖定保護/自動啓動之功能。

腳位定義: SOT-25

Name	P/I/O	Pin#	Description
VDD	P	1	電源供應腳位
Vss	P	2	接地線
FG	O	3	轉速產生器
OUT2	O	4	輸出腳位：2
OUT1	O	5	輸出腳位：1

Winson reserves the right to make changes to improve reliability or manufacturability.

腳位定義: SIP-4L

Name	P/I/O	Pin#	Description
Vcc	P	1	電源供應腳位
OUT1	O	2	輸出腳位：1
OUT2	O	3	輸出腳位：2
Vss	P	4	接地線

腳位定義: SIP-5L

Name	P/I/O	Pin#	Description
Vcc	P	1	電源供應腳位
OUT1	O	2	輸出腳位：1
OUT2	O	3	輸出腳位：2
FG	O	4	轉速產生器
Vss	P	5	接地線

絕對最大承受極限 (at Ta=25° C)

供應電壓	Vcc -----	20V
輸出端最大耐壓	Vout/Vfg -----	25V
感應磁場強度	B -----	Unlimited
反向保護電壓	Vr -----	20V
輸出直流電流	連續	Ic ----- 300mA
	鎖定	Ih ----- 500mA
	瞬間	Ip ----- 1.2A
轉速產生器輸出直流電流	If -----	20mA
工作環境溫度	Ta -----	(-20°C to +100°C)
儲存環境溫度	Ts -----	(-65°C to +150°C)
封裝承受消耗功率	Pd -----	350mw for SOT-25
		500mw for SIP-4L
		500mw for SIP-5L

Winson reserves the right to make changes to improve reliability or manufacturability.

電性特性: (T=+25°C, Vcc=2.8V to 20V)

特性	符號	測試條件	Min	Typ	Max	Units
供應電壓	Vcc	—	2.8	—	20	V
輸出飽和電壓	Vout(sat)	Vcc=20V, Ic=200mA B > Bop	—	0.75	1	V
FG輸出飽和電壓	Vfg(sat)	Vcc=20V, If=10mA B > Bop	—	0.15	0.4	V
輸出端漏電流	Ileakage	Vcc=20V, B < Brp	—	<0.1	10	uA
工作電流	Isupply	Vcc=20V, Output & FG Open	—	5	10	mA
輸出/FG爬升時間	Tr	Vcc=12V, RL=820Ω CL=20Pf	—	3.0	10	us
輸出/FG下落時間	Tf	Vcc=12V, RL=820Ω CL=20Pf	—	0.3	1.5	us
輸出端之差異時間	Δt	Vcc=12V, RL=820Ω CL=20Pf	—	0.3	3	us

功能方塊圖:

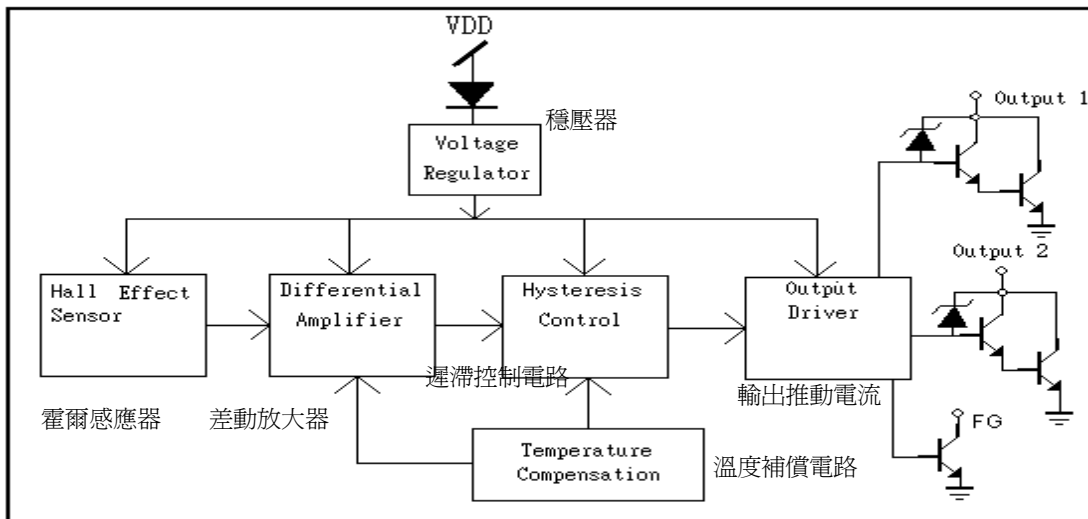

Winson reserves the right to make changes to improve reliability or manufacturability.

磁感特性:

特性	符號	品質	Ta= -20°C to +100°C			Unit
			Min	Typ.	Max	
工作點	Bop	Grade A		25	50	高斯
		Grade B		30	70	
		Grade C		50	120	
釋放點	Brp	Grade A	-50	-25		
		Grade B	-70	-30		
		Grade C	-120	-50		
遲滯窗口	Bop-Brp			40	200	

下單資訊:

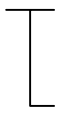
SIP- 4L: WSH411-XPA <input type="checkbox"/> SIP- 5L: WSH411-XPC <input type="checkbox"/> SOT-25: WSH411-XPB <input type="checkbox"/> <div style="text-align: center;">  Elec. Grade </div>	Elec. Grade SIP-4L & SIP-5L: 1: A Grade (50 Gauss) 2: B Grade (70 Gauss) 3: C Grade (120 Gauss) SOT-25: 1: A Grade (50 Gauss) 2: B Grade (70 Gauss)
---	---

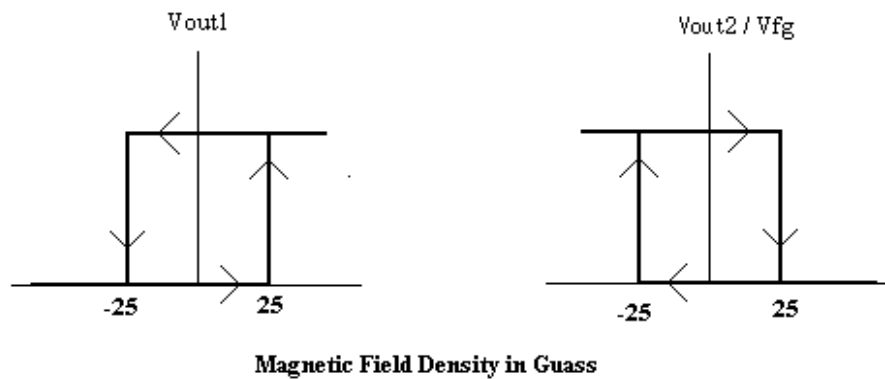
WSH411 Complementary Output1 vs. Output2/Vfg

Winson reserves the right to make changes to improve reliability or manufacturability.

測試電路:

SIP-4L

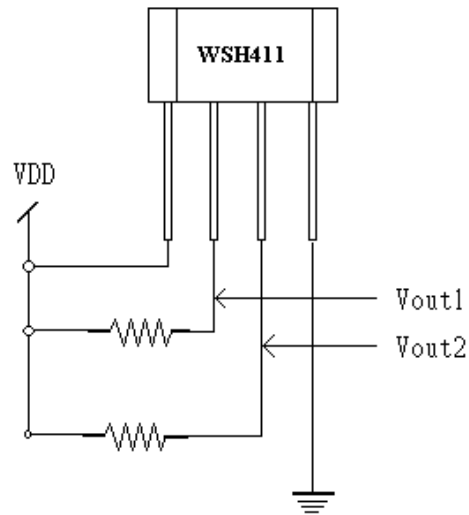

SIP-5L

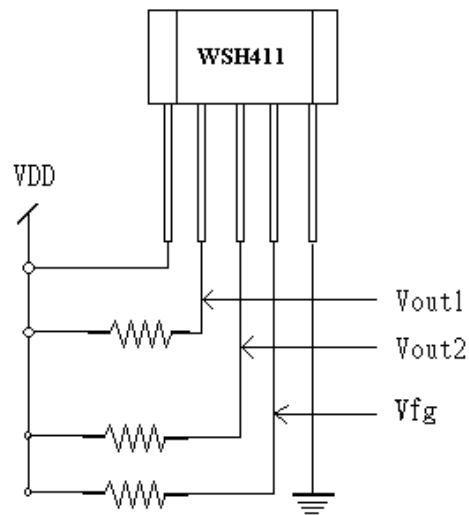

Winson reserves the right to make changes to improve reliability or manufacturability.

SOT-25

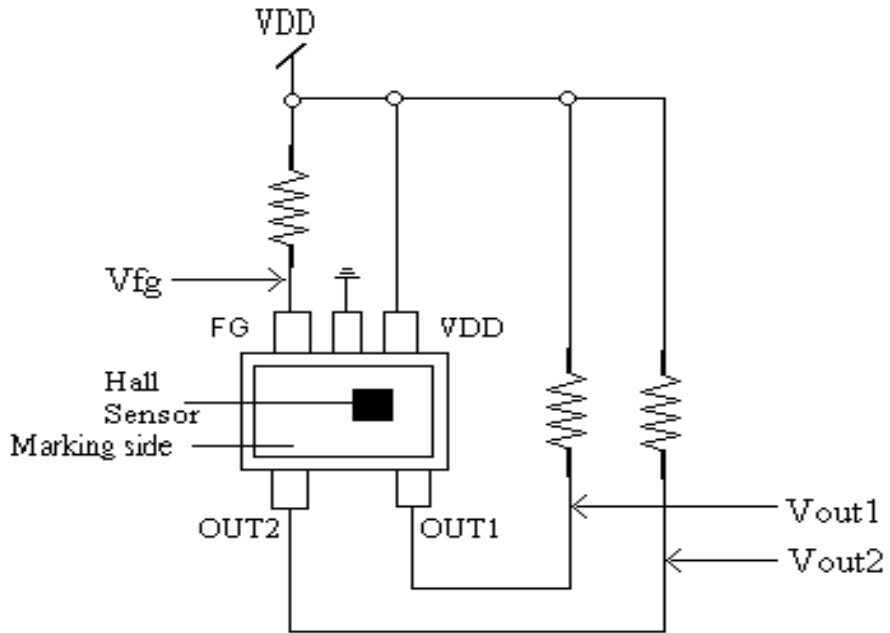

Winson reserves the right to make changes to improve reliability or manufacturability.

封裝資訊:

SOT-25

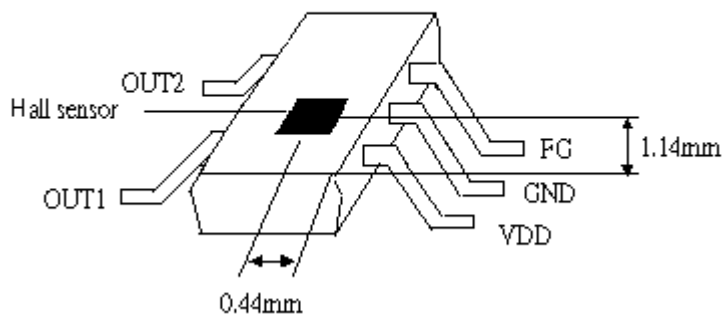
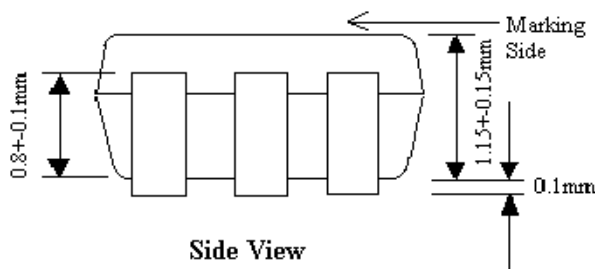
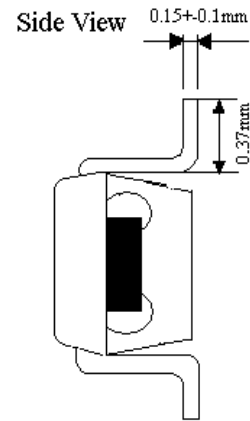
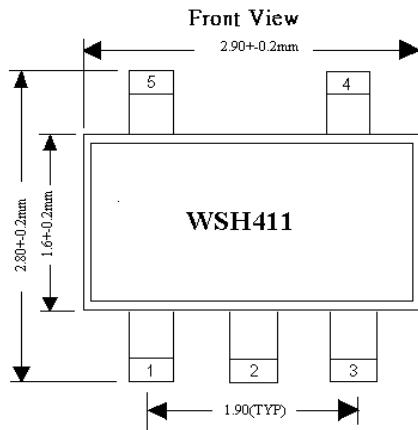

Winson reserves the right to make changes to improve reliability or manufacturability.

SIP-4L

Package Dimension

Hall Sensor Location

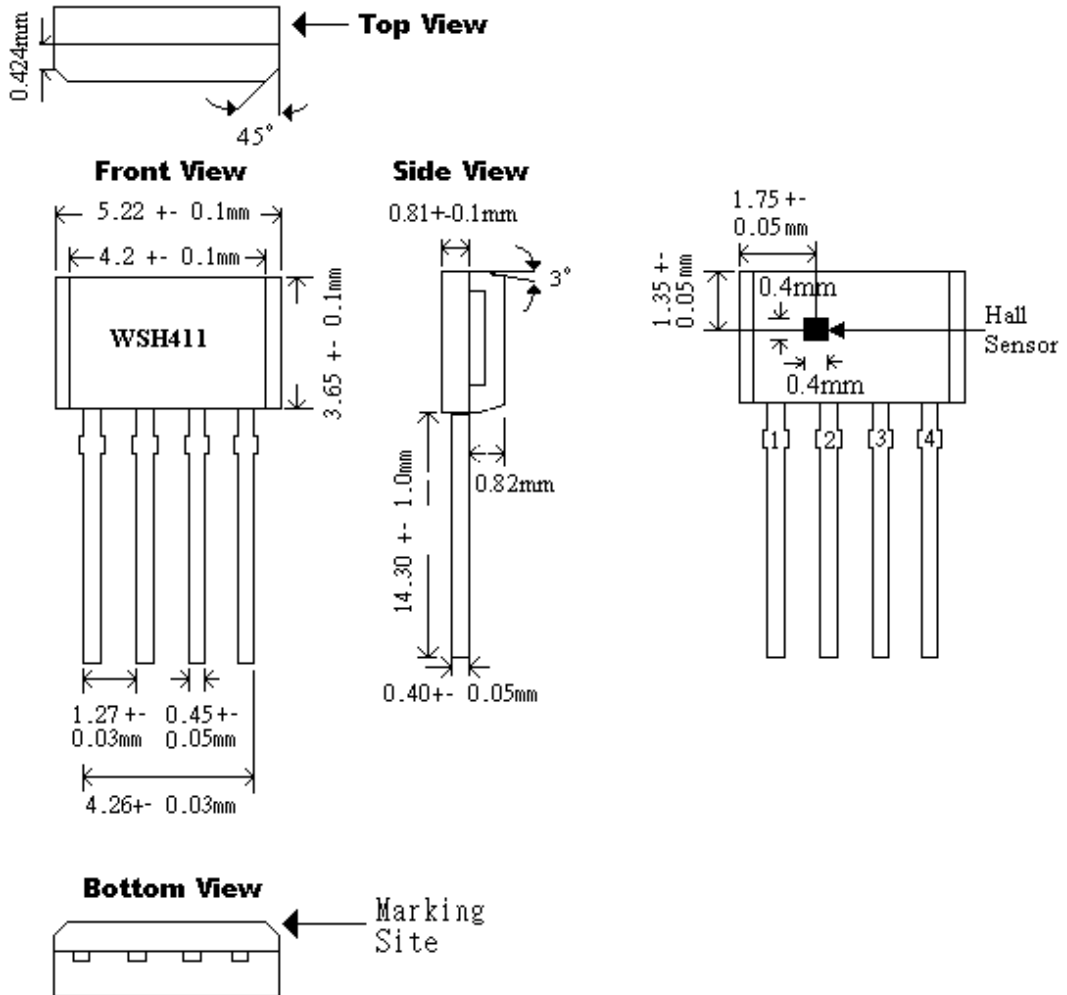

Winson reserves the right to make changes to improve reliability or manufacturability.

SIP-5L

Package Dimension

Hall Sensor Location

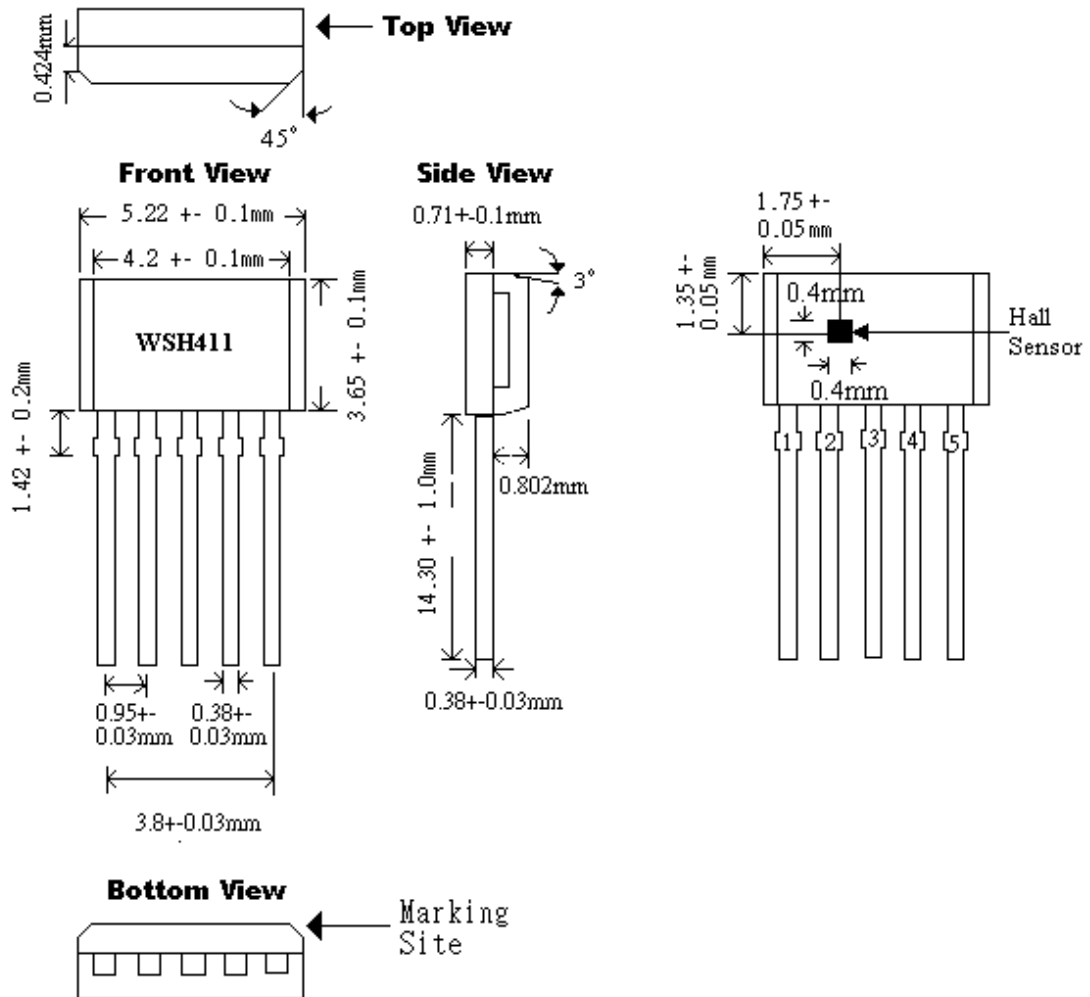

Winson reserves the right to make changes to improve reliability or manufacturability.

應用電路:
SOT-25

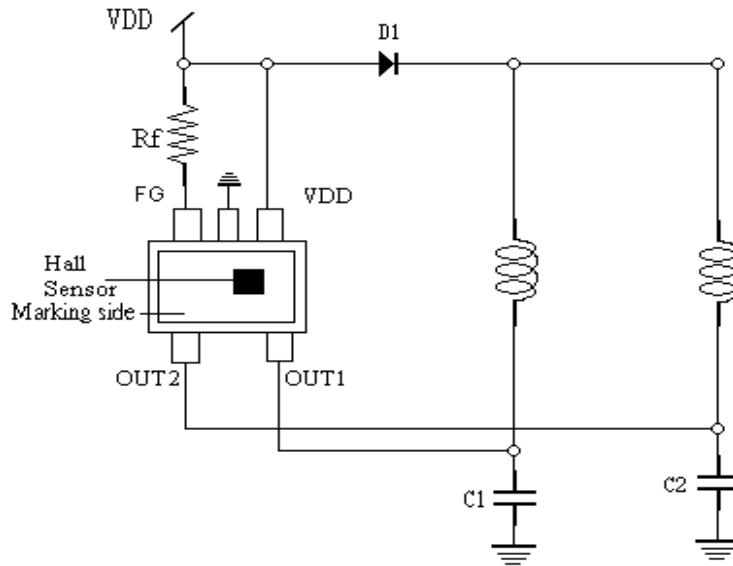

Figure 1.

SIP-4L

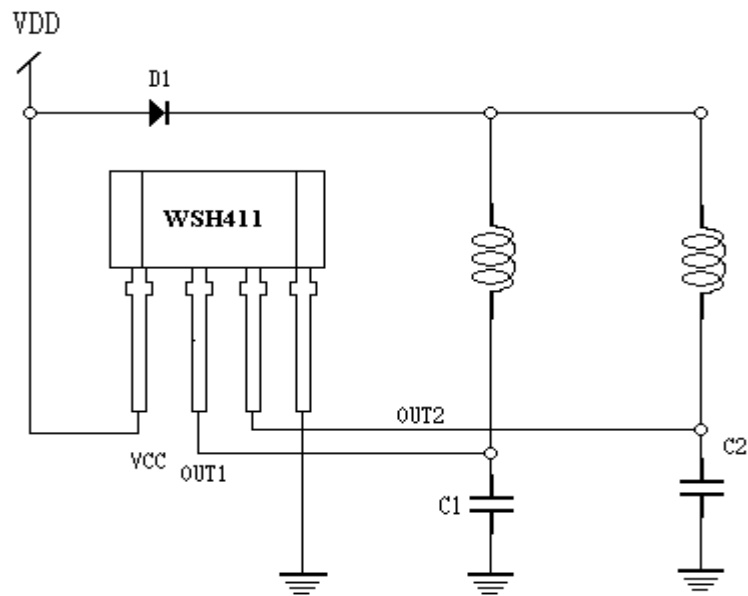

Figure 2.

Winson reserves the right to make changes to improve reliability or manufacturability.

SIP-5L

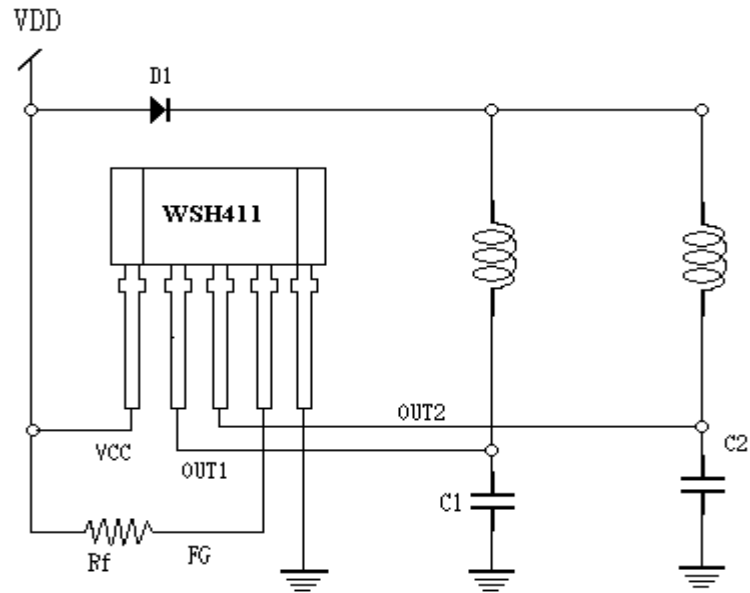

Figure 3.

Winson reserves the right to make changes to improve reliability or manufacturability.