

Single Coil Hall Effect IC with Thermal Lock  
Protection and Auto-restart

產品特性:

- 工作電壓範圍由 2.8 伏特至 14 伏特。
- 內建霍爾感應器。
- 內建穩壓器使工作穩定於不同電壓源。
- 最大輸出可達 350mA。
- 切換時，有較低的電流變換率。
- 有 SOT25,SIP-4L 及 SIP-5L 包裝。
- 內建風扇轉速產生器。
- 內建反向保護二極體可預防反向電壓之誤用,含線圈端部份
- 內建**鎖定溫度保護**與**自動啓動**功能

功能描述:

WSH42FB 是結合霍爾感應器，push-pull 輸出以及轉速產生器在一起的整合型積體電路，它適合使用於單線圈之直流無刷式馬達上，其內部電路包含溫度補償穩壓器、差動放大器、遲滯控制器、push-pull 輸出和可推動 10mA 之負載電流的 open-collector 之 NPN 轉速產生器，另外其內建反向電壓保護二極體可預防反向電壓之誤用。由於已內建轉速產生器且反向電壓保護二極體亦保護到線圈端，因此可以節省所有外加的元件及成本。另一**鎖定溫度保護**與**自動啓動**功能，在高溫 110°C 時會把電源切除,以防止風扇因過熱而導致線圈燒毀且於 105°C 時自動啓動，因此非常適合高轉速的風扇使用。

一般而言，單線圈之馬達運轉效率為雙線圈馬達的 1.1~1.3 倍，其缺點為 IC 本身有過熱之疑慮，WSH42FB 其內部獨特之切換技術已克服此一問題，使其工作環境溫度可適用於 -20°C ~90°C，且工作電壓為 2.8V~14V。

腳位定義: (SIP-4L)

Name	P/I/O	Pin#	Description
Vcc	P	1	電源供應端
DOB	O	2	輸出腳位：1
DO	O	3	輸出腳位：2
Vss	P	4	接地線

Winson reserves the right to make changes to improve reliability or manufacturability.

**腳位定義: (SIP-5L)**

Name	P/I/O	Pin#	Description
Vcc	P	1	電源供應端
DOB	O	2	輸出腳位：1
DO	O	3	輸出腳位：2
FG	O	4	轉速產生器
Vss	P	5	接地線

**腳位定義: (SOT-25)**

Name	P/I/O	Pin#	Description
Vcc	P	1	電源供應端
Vss	P	2	接地線
FG	O	3	轉速產生器
DO	O	4	輸出腳位：2
DOB	O	5	輸出腳位：1

**最大承受極限(at Ta=25° C)**

供應電壓	Vcc -----	14V
輸出端最大耐壓	Vout/Vfg -----	14V
感應磁場強度	B -----	Unlimited
反向保護電壓	Vr -----	8V
輸出直流電流	Ic -----	350mA
轉速產生器輸出直流電流	If -----	10mA
工作環境溫度	Ta -----	(-20°C to +90°C)
儲存環境溫度	Ts -----	(-65°C to +150°C)
封裝後承受消耗功率	Pd -----	350mw for SOT-25 500mw for SIP-4L 500mw for SIP-5L

Winson reserves the right to make changes to improve reliability or manufacturability.

**電性特性:**
**(T=+25°C, Vcc=2.8V to 14V)**

特性	符號	測試條件	Min	Typ	Max	Units
供應電壓	Vcc	—	2.8	—	14	V
輸出飽和電壓	Vout(sat) Vdrive+Vsink	Vcc=5V, Io=150mA	—	0.6	1.5	V
FG輸出飽和電壓	Vfg(sat)	Vcc=5V, If=5mA B > Bop	—	0.1	0.4	V
輸出端漏電流	Ileakage	Vcc=5V, B < Brp	—	<0.1	10	uA
工作電流	Isupply	Vcc=5V, Io=150mA FG “ON”	—	25	35	mA

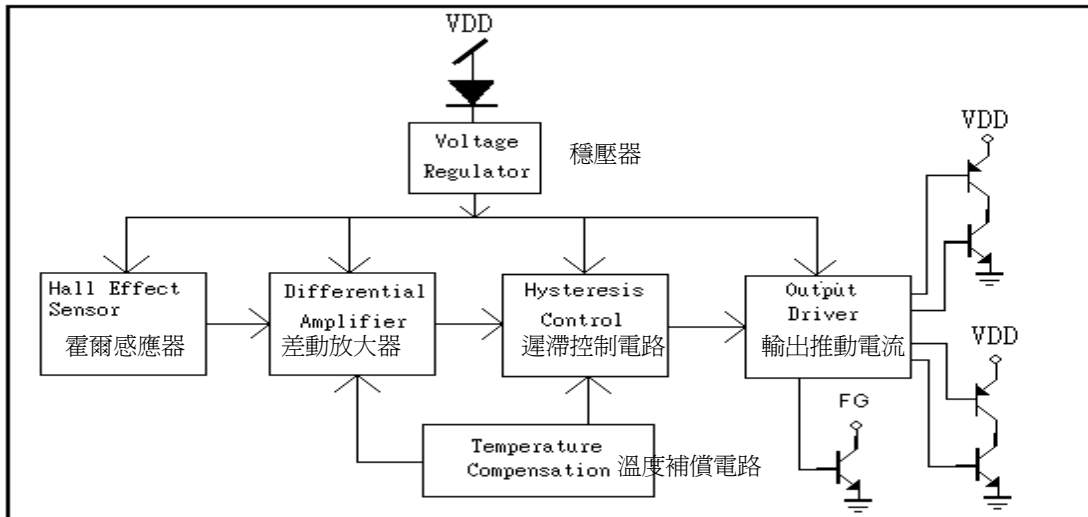
**功能方塊圖:**

**磁感特性:**

特性	符號	品質	Ta= -20°C to +80°C			Unit
			Min	Typ.	Max	
工作點	Bop	Grade A Grade B		50 70	70 100	高斯
釋放點	Brp	Grade A Grade B	-70 -100	-50 -70		高斯
遲滯窗口	Bop-Brp			100	150	高斯

Winson reserves the right to make changes to improve reliability or manufacturability.

下單資訊:

<p><b>SIP -4L:</b> WSH42FB-XPA <input type="checkbox"/></p> <p><b>SIP -5L:</b> WSH42FB-XPC <input type="checkbox"/></p> <p><b>SOT-25:</b> WSH42FB-XPD <input type="checkbox"/></p> <p style="text-align: center;">└─┬─┘ Elec. Grade</p>	<p>Elec. Grade</p> <p><b>SIP-4L &amp; SIP-5L:</b></p> <p>1: A Grade (70 Gauss)</p> <p>2: B Grade (100 Gauss)</p> <p><b>SOT-25:</b></p> <p>1: A Grade (70 Gauss)</p> <p>2: B Grade (100 Gauss)</p>
---	---

**WSH42FB Complementary Output1/Vfg vs. Output2**

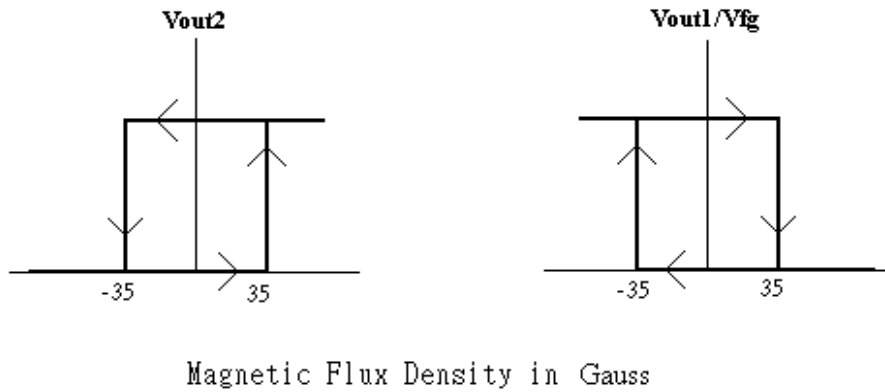

測試電路:

**1. SIP-4L**

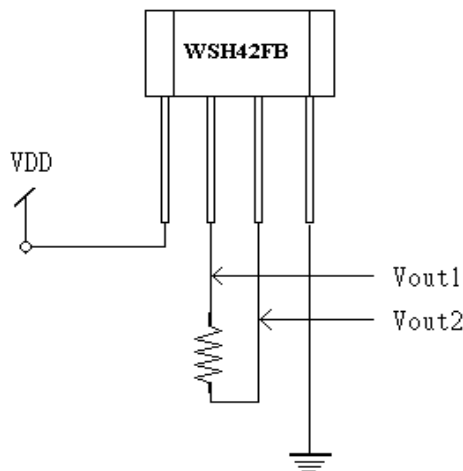

Winson reserves the right to make changes to improve reliability or manufacturability.

2.SIP-5L

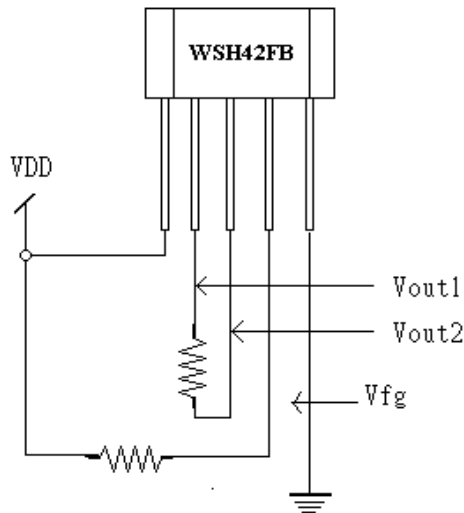

3. SOT-25

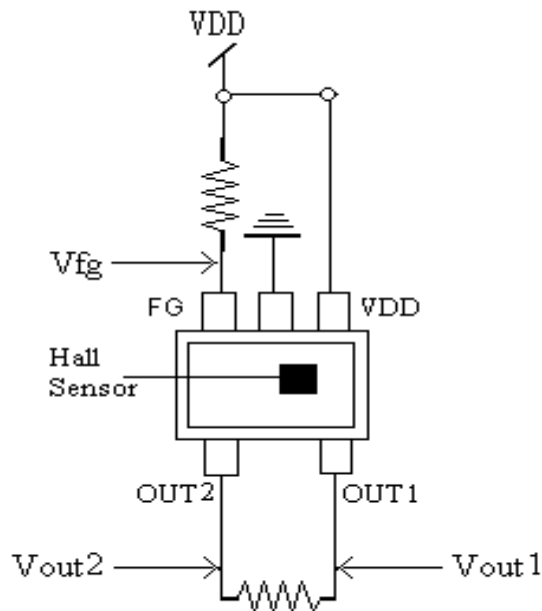

Winson reserves the right to make changes to improve reliability or manufacturability.

封裝資訊:

1. SIP-4L

**Package Dimension**

**Hall Sensor Location**

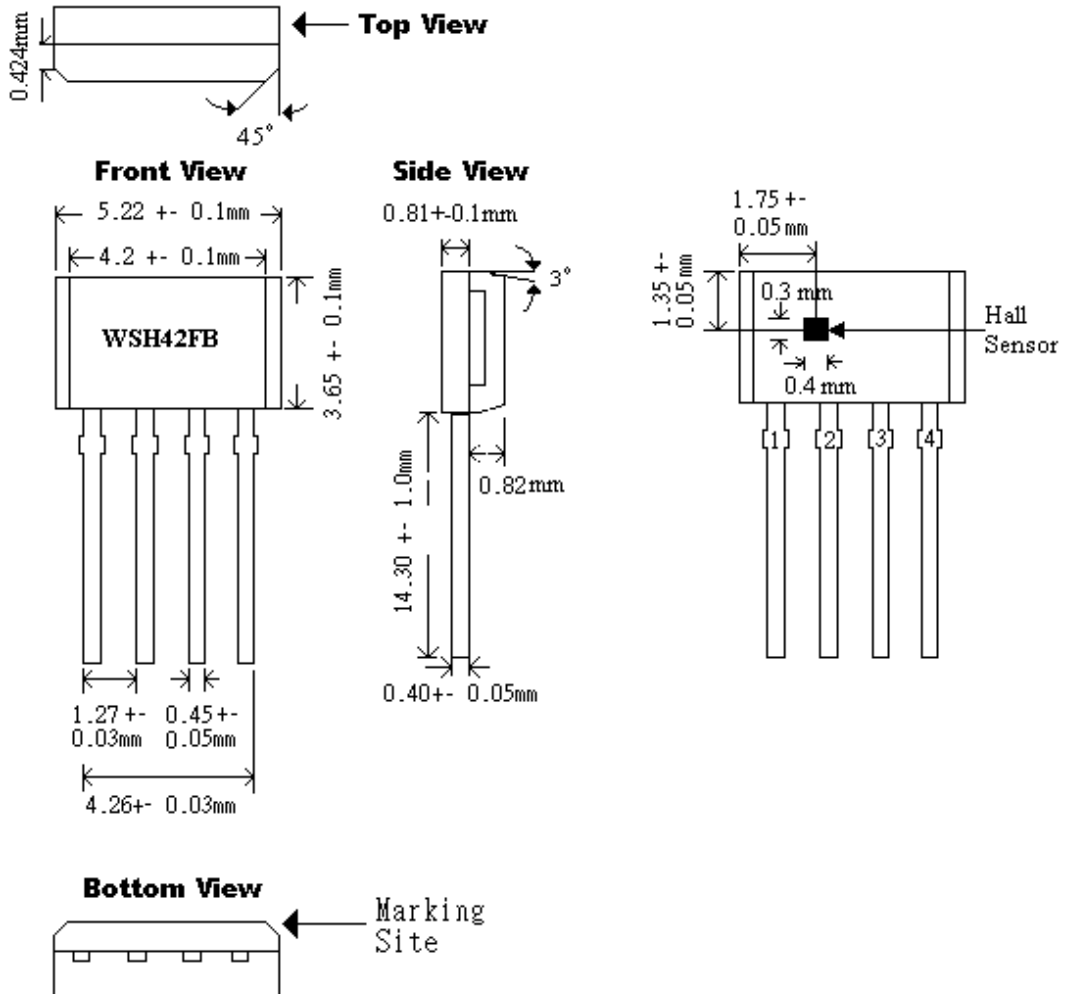

Winson reserves the right to make changes to improve reliability or manufacturability.

2. SIP-5L

**Package Dimension**

**Hall Sensor Location**

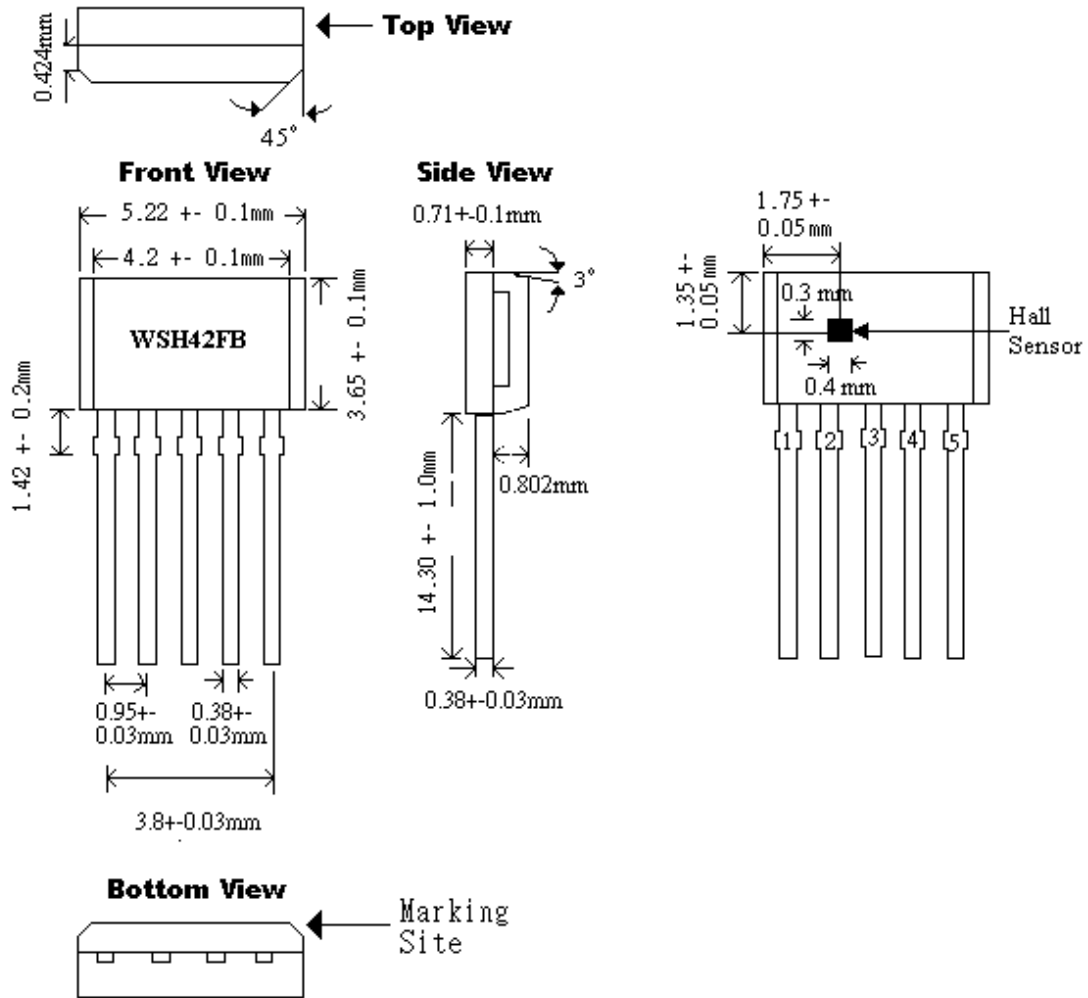

Winson reserves the right to make changes to improve reliability or manufacturability.

3. SOT-25

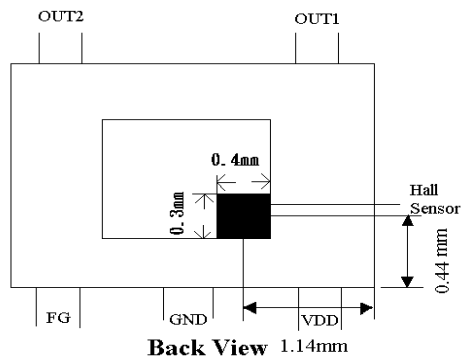
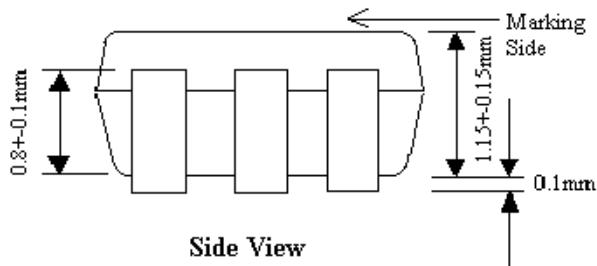
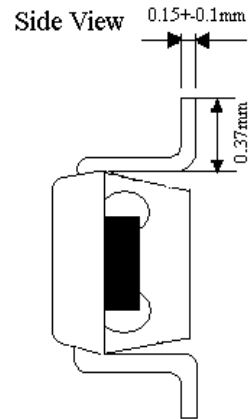
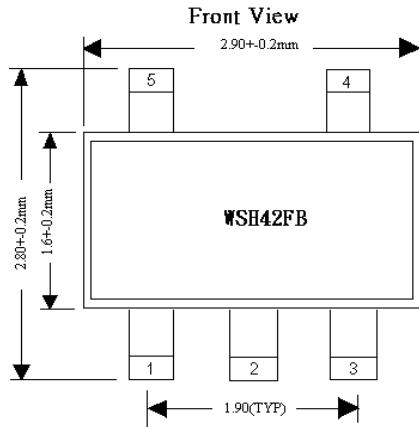

Winson reserves the right to make changes to improve reliability or manufacturability.

應用電路：

1. SIP-4L

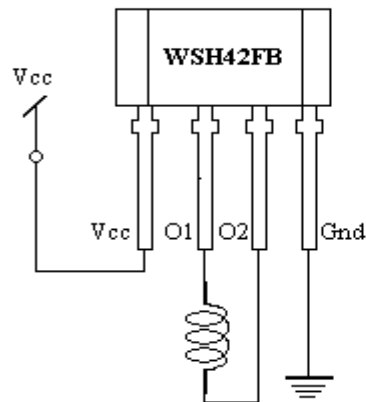

Figure 1.

2.SIP-5L

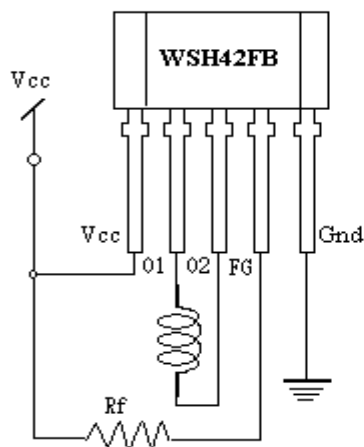

Figure 2.

Winson reserves the right to make changes to improve reliability or manufacturability.

3-1. SOT-25

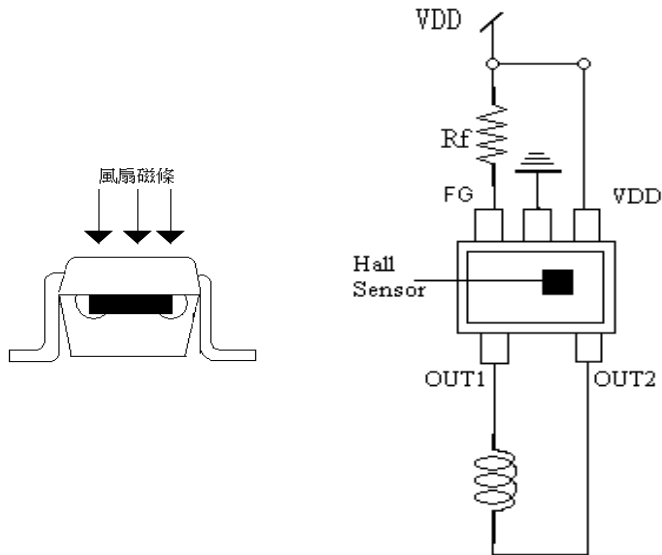

Figure 3.

3-2. SOT-25

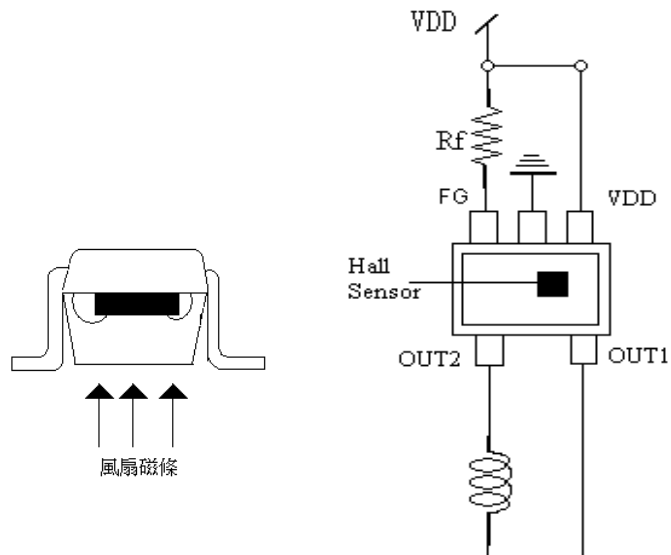

Figure 4.

Winson reserves the right to make changes to improve reliability or manufacturability.