

Hall Effect Base Linear Current Sensor

Features:

- Diameter 9.0mm conductor through hole
- Output voltage proportional to AC and DC current
- Wide sensing current range 0~100A at 5V volt
- High sensitivity 22mV/A
- Wide operating voltage range 3.0~12 V.
- Low operating current 3mA
- Isolation voltage 4000V
- Ratiometric output from supply voltage
- 23K Hz Bandwidth
- Two bronze sticks for easy soldering on PCB



Functional Description:

The Winson WCS1600 current sensor provides economical and precise solution for both DC and AC current sensing in industrial, commercial and communications systems. The unique package provides easy implementation without breaking original system and makes current sensing possible. Typical applications include motor control, load detection and management, over-current fault detection and any intelligent power management system etc...

The WCS1600 consists of a precise, low-temperature drift linear hall sensor IC with temperature compensation circuit and a diameter 9.0mm through hole. Users can use system's own electric wire by pass it through this hole to measure passing current. This design allows system designers to monitor any current path without breaking or changing original system layout at all. Any current flowing through this hole will generate a magnetic field which is sensed by the integrated Hall IC and converted into a proportional voltage.

The terminals of the conductive path are electrically isolated from the sensor leads. This allows the WCS1600 current sensor to be used in applications requiring electrical isolation without the use of opto-isolators or other costly isolation techniques and make system more competitive in cost.

Winson reserves the right to make changes to improve reliability or manufacturability.

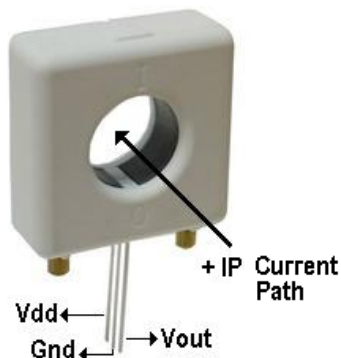

ABSOLUTE MAXIMUM RATING

Supply Voltage, Vdd	14V
Pass Through Wire Diameter	9.0mm
Output Current Sink	0.4mA
Output Current Source	2mA
Basic Isolation Voltage	4000V
Operating Temperature Range	
Ta	-20°C to +125°C
Storage Temperature Range	
Ts	-65°C to +150°C
Power Dissipation Pd	1 W

Vout vs. Primary Current

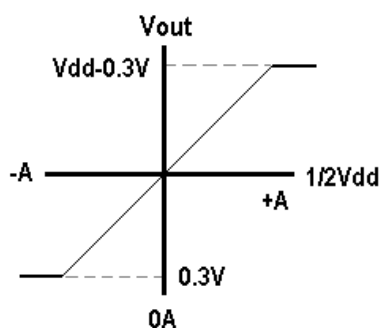

Order Information

(Vdd=5V)

Part No.	Sensitivity	Current range
WCS1600	22 mV/A	DC: ±0~100 A
		AC: rms 70 A

Function Block:

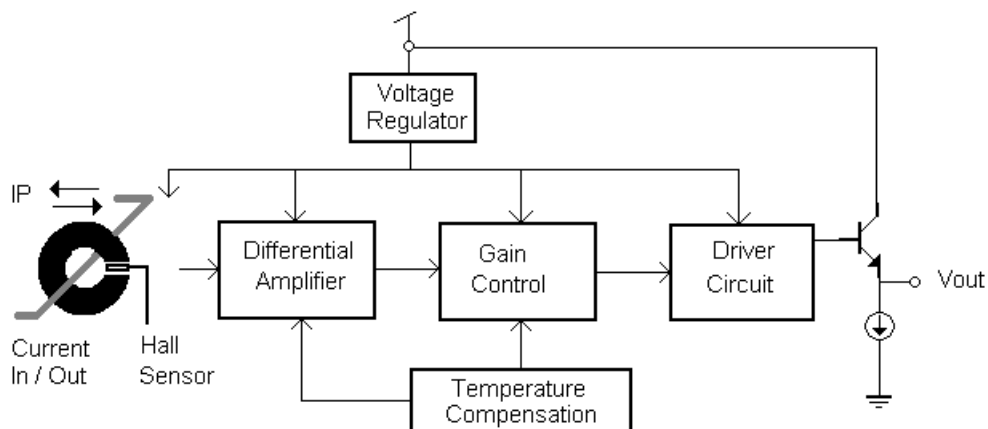

Winson reserves the right to make changes to improve reliability or manufacturability.

Electrical Characteristics: (T=+25°C, Vdd=5.0V)

Characteristic	Symbol	Test Conditions	Min	Typ	Max	Units
Supply Voltage	Vdd	—	3.0	—	12	V
Supply Current	I _{supply}	IP = 0 A	—	3.5	6.0	mA
Zero Current Vout	V _{0G}	IP = 0 A (DC Mode)	2.4	2.5	2.6	V
Conductor Through Hole	—	—	—	9.0	—	mm ²
Sensitivity	Sens	IP = +/-10 A	18	22	25	mV/A
Bandwidth	BW	—	—	23	—	kHz
Measurable Current Range	MR	Vdd=5V (DC Mode)	—	±100	—	A
		Vdd=5V (AC RMS)	—	70	—	
Temperature Drift	ΔV _{out}	IP = 0 A	—	±0.3	—	mV/°C
Output Noise	V _{Np-p}	IP = 0 A	—	5	—	mV
	V _{Np-p(0.01uF)}	IP = 0 A, C = 0.01uF	—	1	—	

1. All output-voltage measurements are made with a voltmeter having an input impedance of at least 100kΩ
2. Do not apply any 'resistor load' on output pin, it will degrade IC's performance.

Characteristic Diagrams:

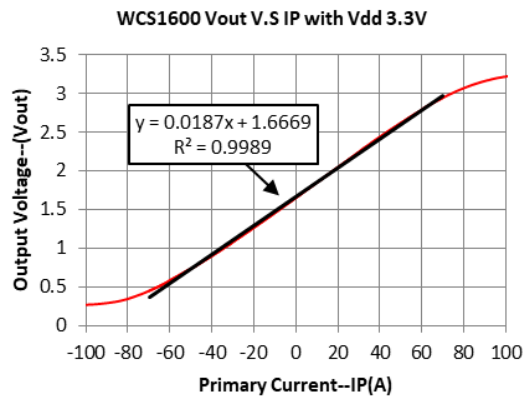
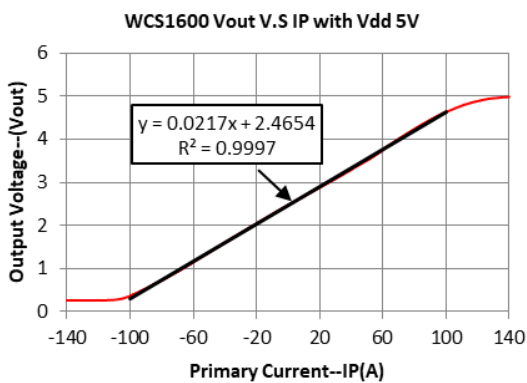
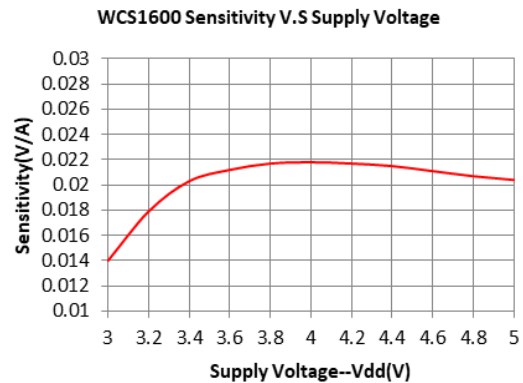
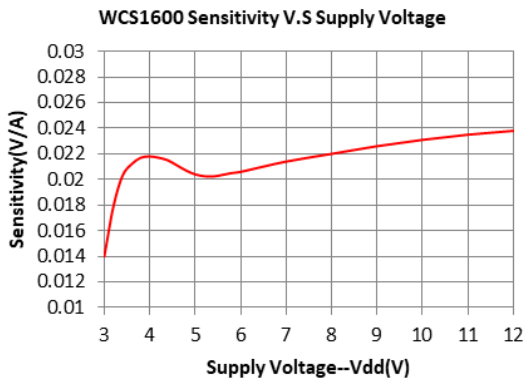

Winson reserves the right to make changes to improve reliability or manufacturability.

WCS1600 Sensitivity standardization of 30°C (5V) V.S Temperature

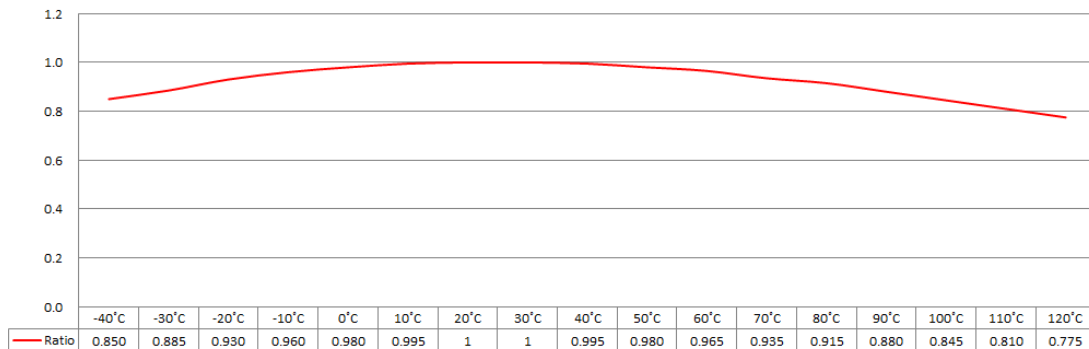

WCS1600 Sensitivity standardization of 30°C (3.3V) V.S Temperature

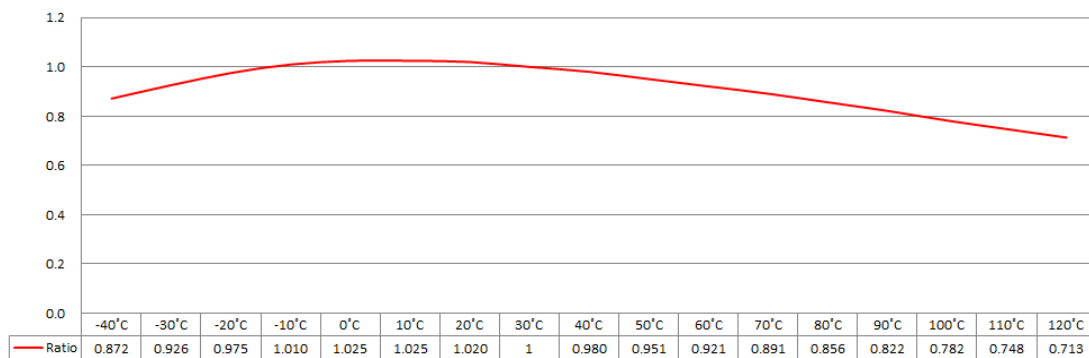

Application Circuit:

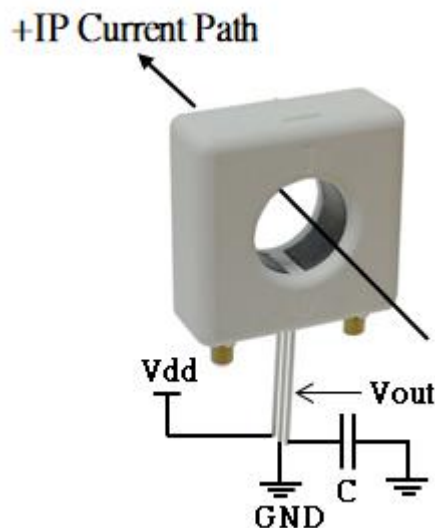

Capacitor **C**(0.01uF~0.1uF) is recommend to be connected between Vout and GND to reduce output noise.

Winson reserves the right to make changes to improve reliability or manufacturability.

Package Information:

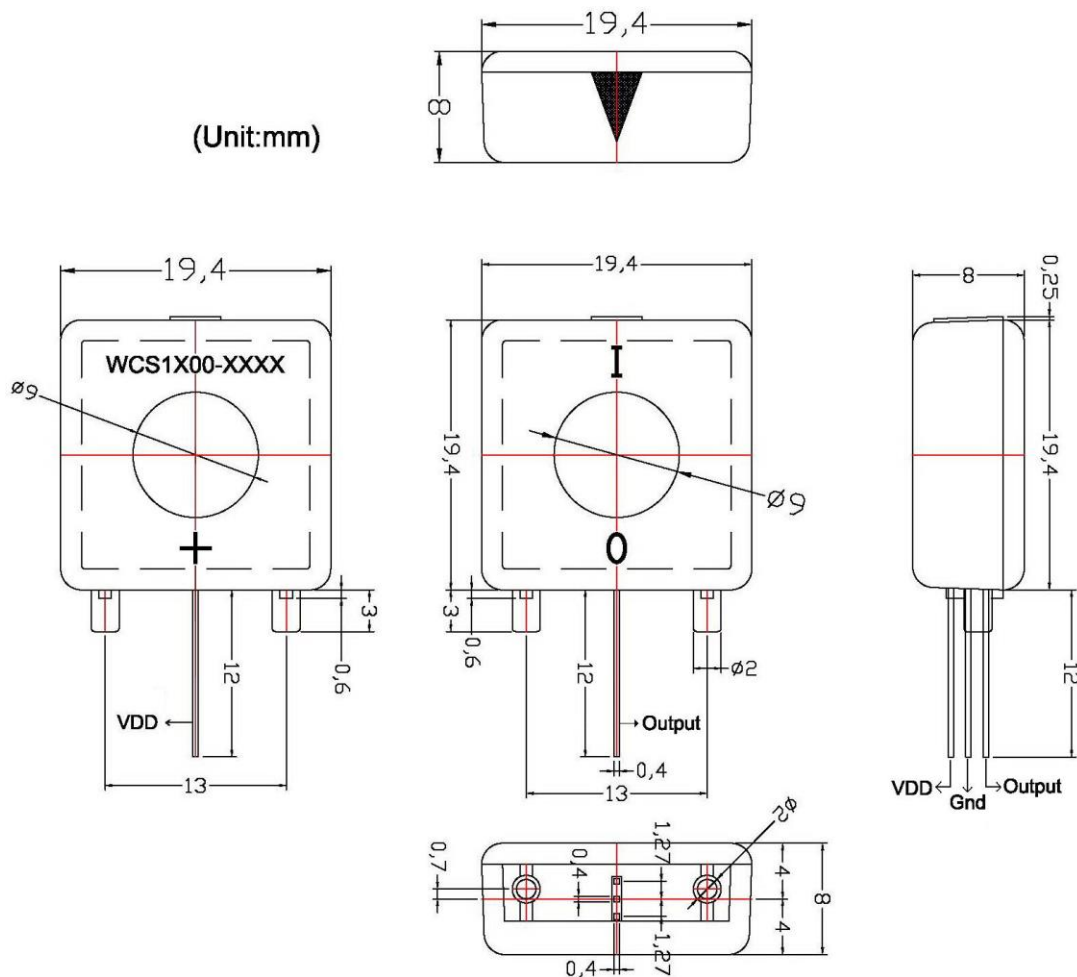

Winson reserves the right to make changes to improve reliability or manufacturability.