Linear Hall Effect Sensor IC

Features:

- Wide operating range 3.0~12V, -40°C~125°C
- Flat Response to 23kHz
- Low Null Gauss output drift, typical -0.4m V/°C (- 0.016 %/°C)
- Wide sensible magnetic field range on different supplied voltage
±1,000 Gauss on 5V supplied voltage
±3,500 Gauss on 12V supplied voltage. Low operating current 3mA
- Two package styles TO-92S/SOT-23 available.

Functional Description :

The W135 integrates Hall sensing element, linear amplifier, sensitivity controller and emitter follower output stage. It accurately tracks extremely small change in magnetic flux density –generally too small to operate Hall effect switch.

W135 can be applied as current sensor, tooth sensor, proximity detectors and motion detectors. As sensitive monitor of magnetic flux, it can effectively measure a system's performance with negligible system loading while providing isolation from contaminated and electrically noisy environments.

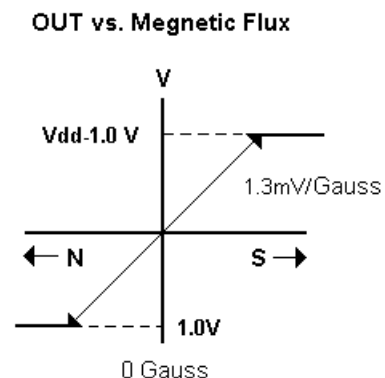
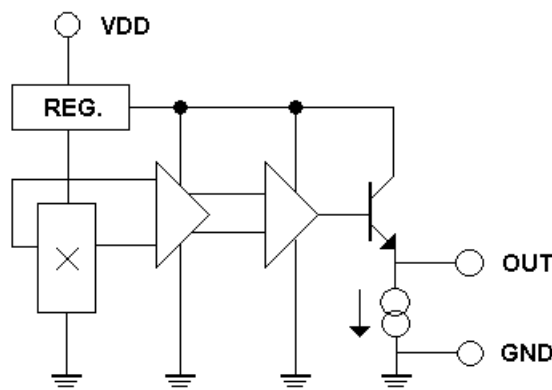

Winson reserves the right to make changes to improve reliability or manufacturability.

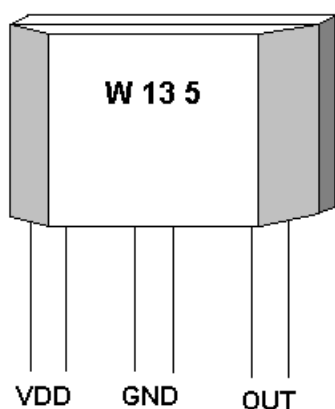

ABSOLUTE MAXIMUM RATING

Supply Voltage, Vdd ----- 14V
 Magnetic Flux Density, B ----- **Unlimited**
 Output Driving Current, Iout ----- 5mA
 Operating Temperature Range
 Ta ----- -40°C to +125°C
 Storage Temperature Range
 Ts ----- -65°C to +150°C
 Power Dissipation Pd
 TO-92S ----- 450mW
 SOT-23 ----- 350mW

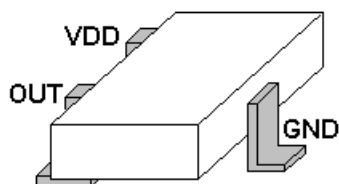

ORDER INFORMATION

WSH135-XPAN □ (TO-92)	1: A Grade
WSH135-XPCN □ (SOT23)	2: B Grade
↑ Grade	

Electrical Characteristics:

(T=+25°C, Vdd=5.0V)

Characteristic	Symbol	Test Conditions	Min	Typ	Max	Units
Supply Voltage	Vcc	—	3.0	—	12	V
Supply Current	Isupply	B=0 Gauss	—	3.5	6.0	mA
Quiescent Vout	V0G	B=0 G (Grade A)	2.45	2.5	2.55	V
		B=0 G (Grade B)	2.35	2.5	2.65	V
Sensitivity	ΔVout	B= 0 to ± 1000 G	1.0	1.3	1.6	mV/G
Bandwidth	BW		—	23	—	kHz
Measurable Gauss Range	MGR	Vdd=5V	—	±1000	—	Gauss
		Vdd=12V	—	±3500	—	
Temperature Drift	ΔVout	B=0 Gauss	—	- 0.4	—	mV/°C

All output-voltage measurements are made with a voltmeter having an input impedance of at least 100kΩ

Winson reserves the right to make changes to improve reliability or manufacturability.

Package Information:

TO92S:

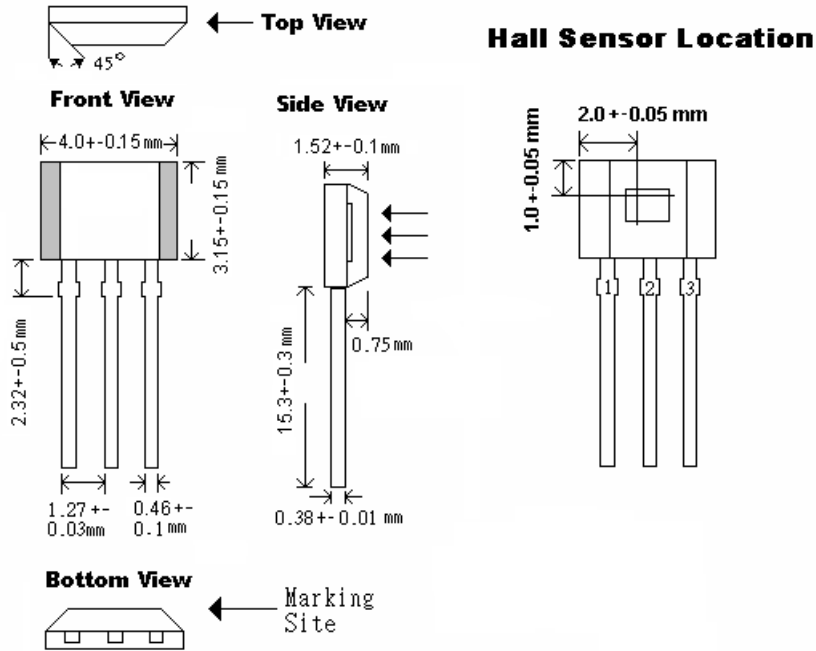

SOT23:

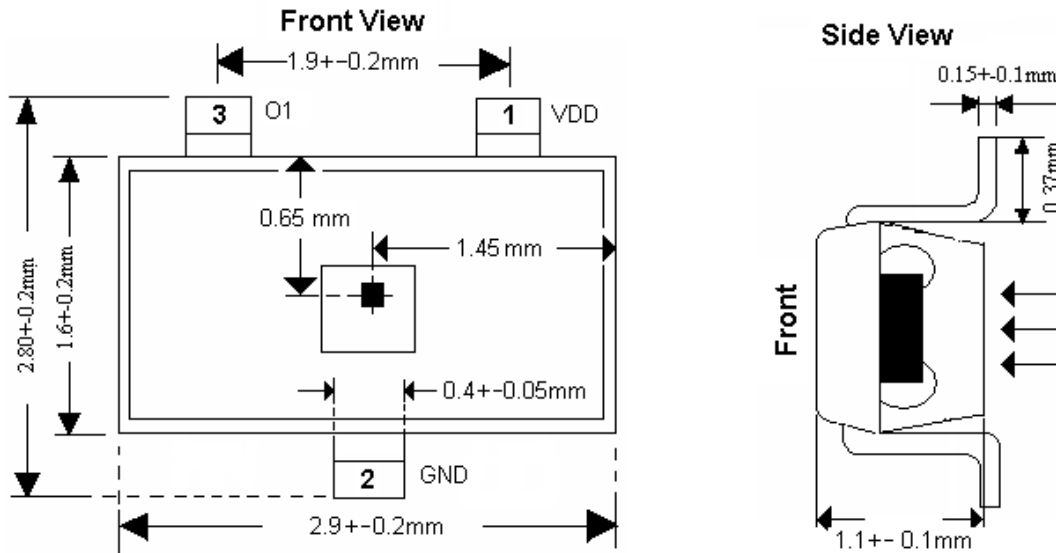

Winson reserves the right to make changes to improve reliability or manufacturability.

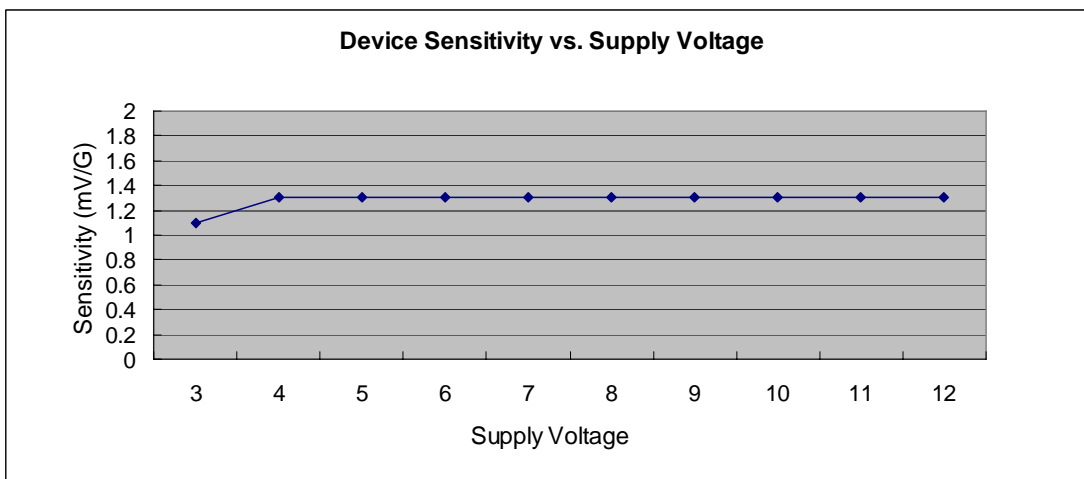
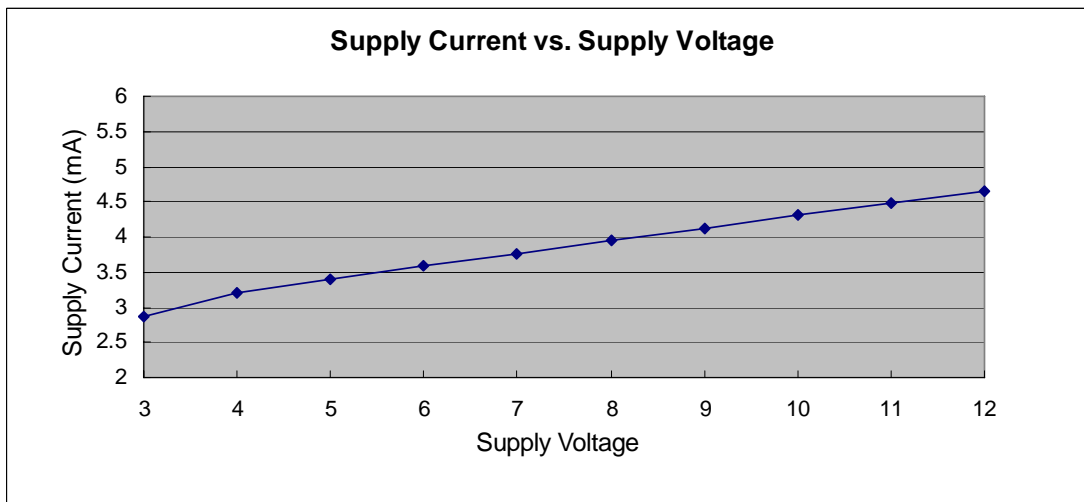
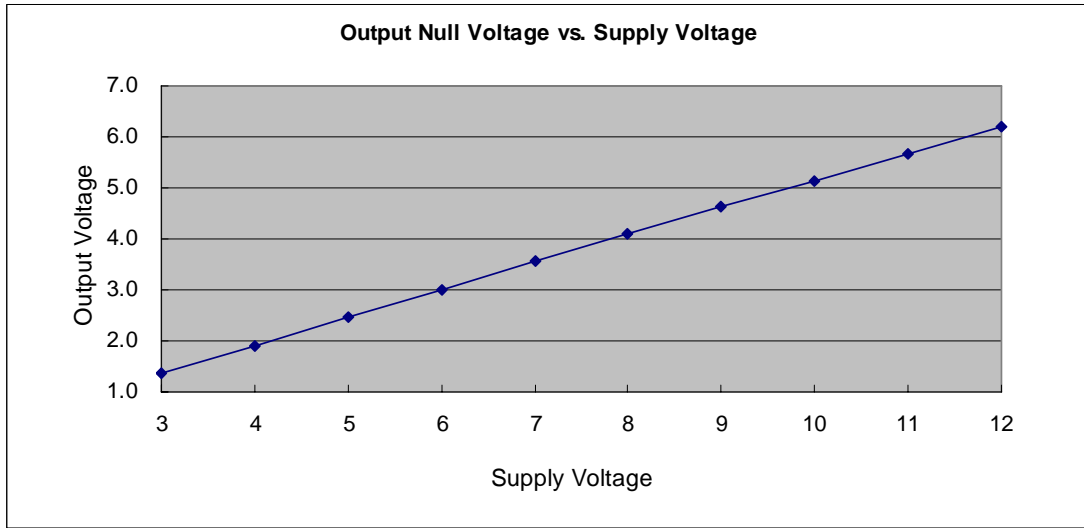

Winson reserves the right to make changes to improve reliability or manufacturability.

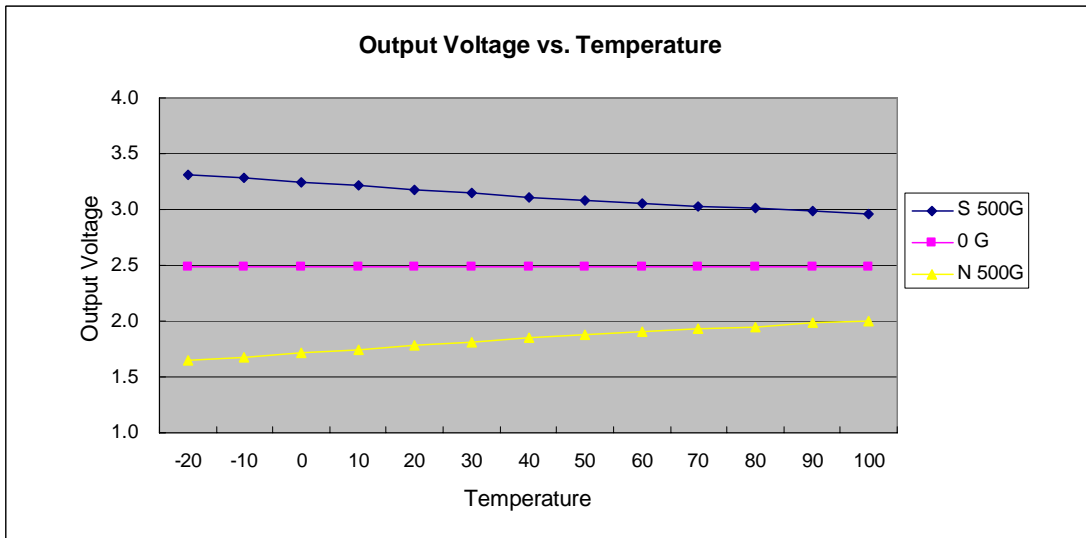
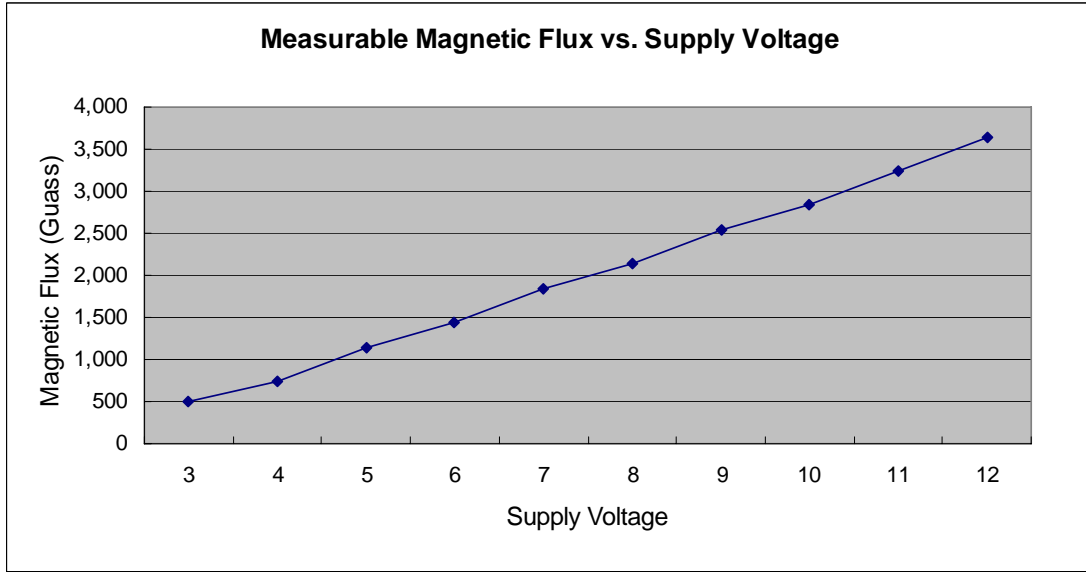

Winson reserves the right to make changes to improve reliability or manufacturability.