Hall Effect Sensor IC with Complementary Output Drivers and Frequency Generator

Features:

- Operate from 2.8V to 20V supply voltage.
- On-chip Hall sensor.
- Internal bandgap regulator allows temperature compensated operations and a wide operating voltage range.
- High output sinking capability up to 400mA for driving large load.
- Lower current change rate reduces the peak output voltages during switching.
- Available in rugged low profile SOT-25 , SIP-4L packages.
- Built-in FG output.
- Built-in protection diode for reverse power supply fault.

General Description:

WSH41FC is designed to integrate Hall sensor with complementary output drivers and frequency generator together on the same chip, it is suitable for speed measurement, revolution counting, positioning, and DC brushless motors. It includes a temperature compensated voltage regulator, a differential amplifier, a Hysteresis controller, two open-collector output drivers capable of sinking 400mA current load and an open-collector frequency generator capable of sinking 10mA current load. An on-chip protection diode is implemented to prevent reverse power fault.

The temperature-dependent bias increases the supply voltage of the hall plates and adjusts the switching points to the decreasing induction of magnets at higher temperatures. Subsequently, the open collector output switches to the appropriate state. WSH41FC are rated for operation over temperature range from -20°C to 125°C and voltage ranges from 2.8V to 20V.

In **SOT-25** package, the built-in FG function can save fan system a lot of cost. It is a very economical solution when fan system need FG signal.



Pin Descriptions: SOT-25

Name	P/I/O	Pin#	Description
VDD	P	1	Positive Power Supply
Vss	P	2	Ground
FG	O	3	Frequency Generator
OUT2	O	4	Output Pin 2
OUT1	O	5	Output Pin 1

Pin Descriptions: SIP-4L

Name	P/I/O	Pin#	Description
Vcc	P	1	Positive Power Supply
OUT1	O	2	Output Pin #1
OUT2	O	3	Output Pin #2
Vss	P	4	Ground

Absolute Maximum Rating (at Ta=25° C)

Supply Voltage	Vcc -----	20V
Output / FG breakdown Voltage	Vout/Vfg -----	25V
Magnetic flux density	B -----	Unlimited
Reverse Protection Voltage	Vr -----	20V
Output Current continuous	Ic -----	300mA
Hold current	Ih -----	400mA
Peak current	Ip -----	800mA
FG ON Current (continuous)	If -----	20mA
Operating Temperature Range	Ta -----	(-20°C to +125°C)
Storage Temperature Range	Ts -----	(-65°C to +150°C)
Package Power Dissipation	Pd -----	350mw for SOT-25 500mw for SIP-4L

Winson reserves the right to make changes to improve reliability or manufacturability.

Electrical Characteristics: (T=+25°C, Vcc=2.8V to 20V)

Characteristic	Symbol	Test Conditions	Min	Typ	Max	Units
Supply Voltage	Vcc	—	2.8	—	20	V
Output Saturation Voltage	Vout(sat)	Vcc=20V, Ic=200mA B > Bop	—	0.2	0.4	V
FG Saturation Voltage	Vfg(sat)	Vcc=20V, If=10mA B > Bop	—	0.15	0.4	V
Output Leakage Current	Ileakage	Vcc=20V, B < Brp	—	<0.1	10	UA
Supply Current	Isupply	Vcc=20V, Output & FG Open	—	14	25	MA
Output / FG Rising Time	Tr	Vcc=12V, RL=820Ω CL=20Pf	—	3.0	10	Us
Output / FG Falling Time	Tf	Vcc=12V, RL=820Ω CL=20Pf	—	0.3	1.5	Us
Output / FG Time Differential	Δt	Vcc=12V, RL=820Ω CL=20Pf	—	0.3	3	Us

Function Block:

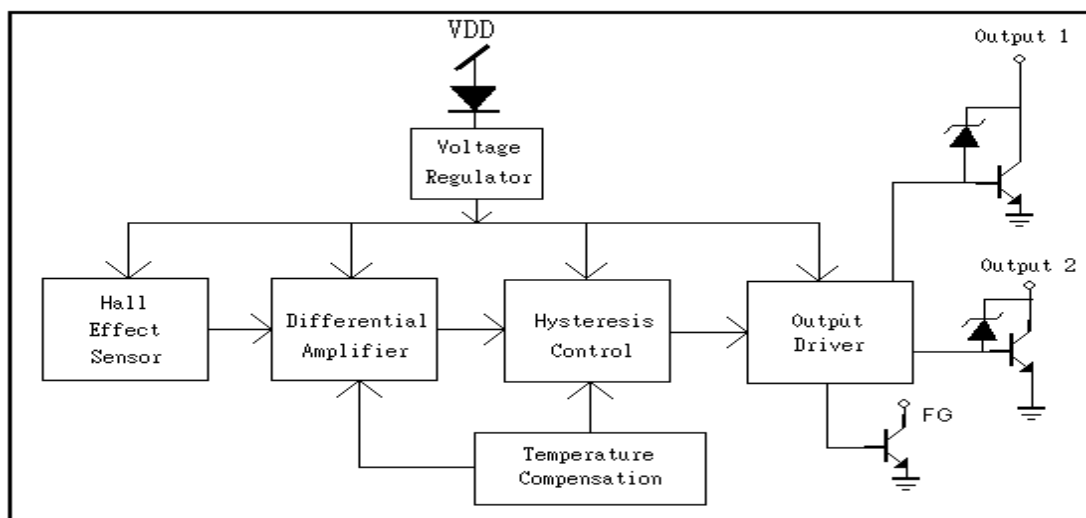

Winson reserves the right to make changes to improve reliability or manufacturability.

Magnetic Characteristics:

Characteristics	Symbol	Quantity	Ta= -20°C to +90°C			Unit
			Min	Typ.	Max	
Operate Point	Bop	Grade A		30	50	Gauss
		Grade B		40	70	
		Grade C		70	120	
Release Point	Brp	Grade A	-50	-30		Gauss
		Grade B	-70	-40		
		Grade C	-120	-70		
Hysteresis Window	Bop-Brp			40	150	Gauss

Ordering Information:

<p>SIP- 4L: WSH41FC-XPAN <input type="checkbox"/></p> <p>SOT-25: WSH41FC-XPDN <input type="checkbox"/></p> <p style="margin-left: 100px;">└─┬─┘ Elec. Grade</p> <p>N: No-Lead process</p>	<p>Elec. Grade</p> <p>SIP-4L :</p> <p>1: A Grade (50 Gauss)</p> <p>2: B Grade (70 Gauss)</p> <p>3: C Grade (120 Gauss)</p> <p>SOT-25:</p> <p>1: A Grade (50 Gauss)</p> <p>2: B Grade (70 Gauss)</p>
--	--

WSH41FC Complementary Output1 vs. Output2/Vfg

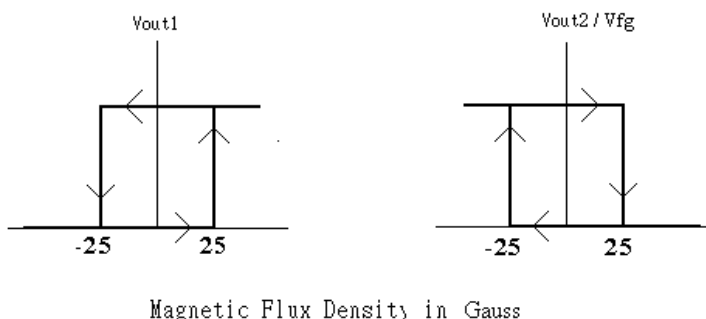

Winson reserves the right to make changes to improve reliability or manufacturability.

Test Circuit:
SIP-4L

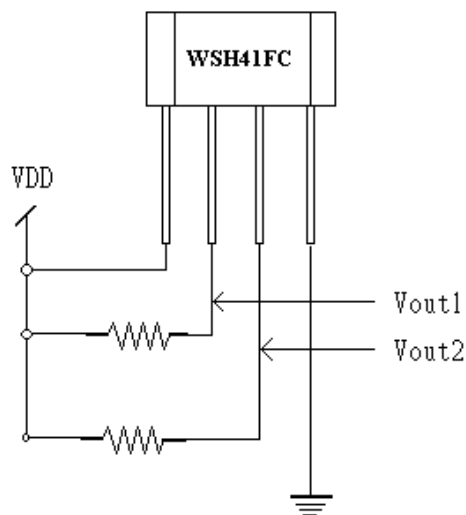

SOT-25

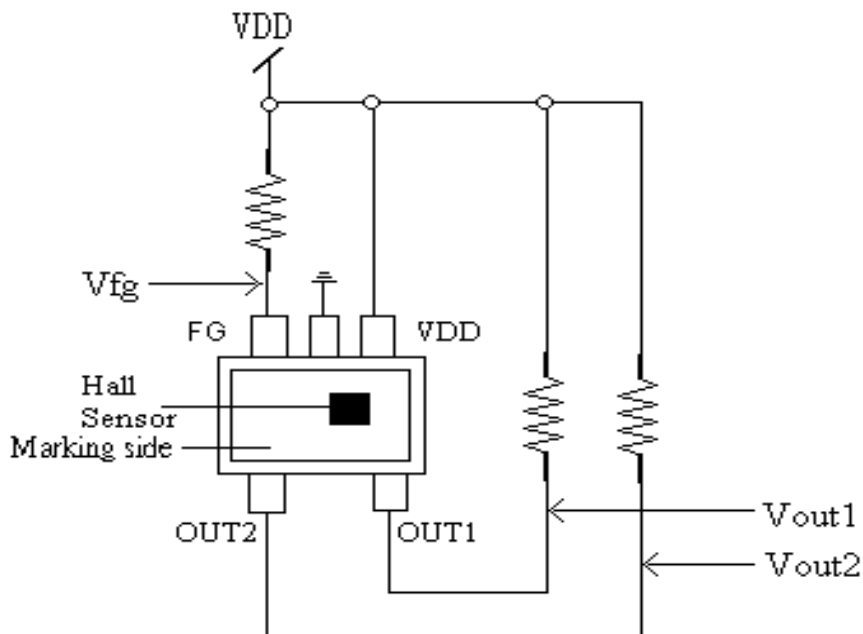

Winson reserves the right to make changes to improve reliability or manufacturability.

Package Information:

SOT-25

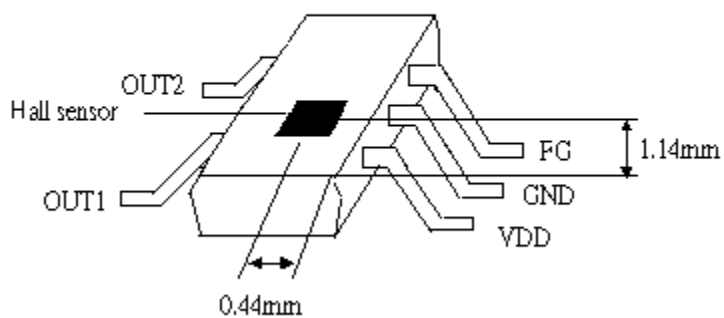
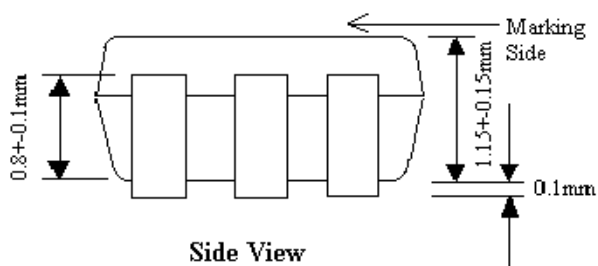
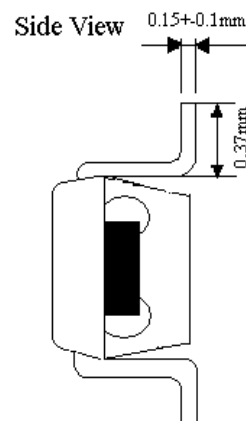
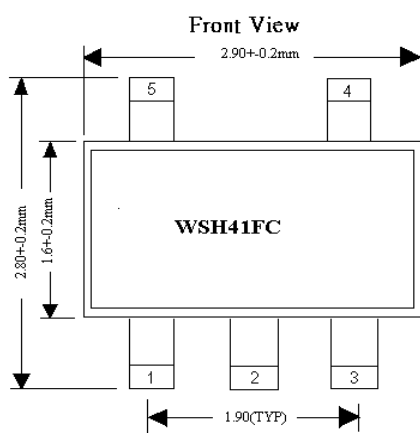

Winson reserves the right to make changes to improve reliability or manufacturability.

SIP-4L

Package Dimension

Hall Sensor Location

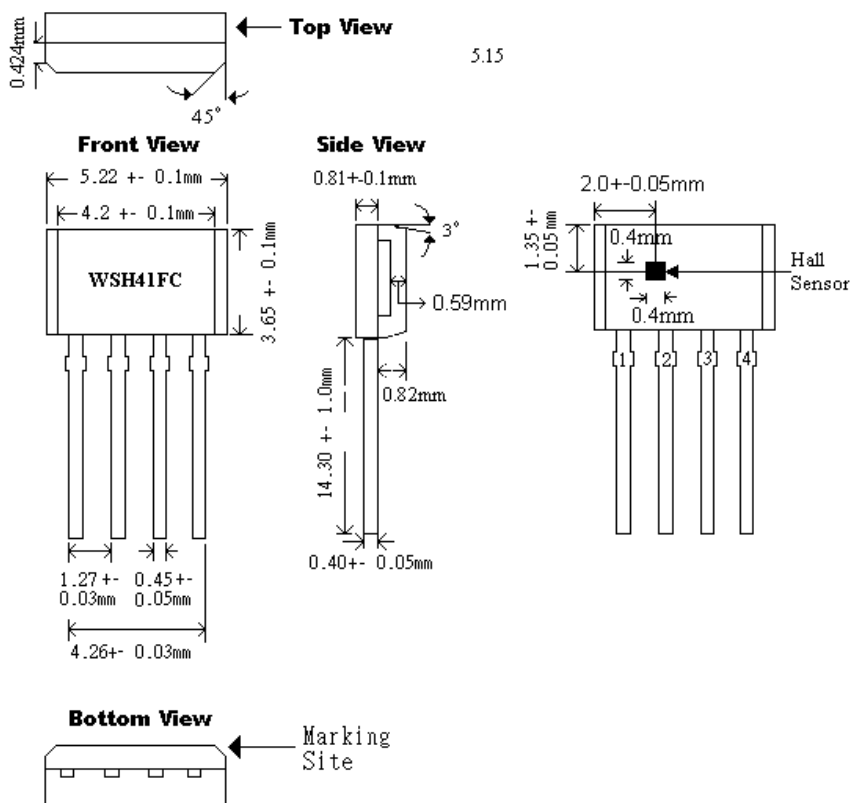

Winson reserves the right to make changes to improve reliability or manufacturability.

Application Circuit:
SOT-25

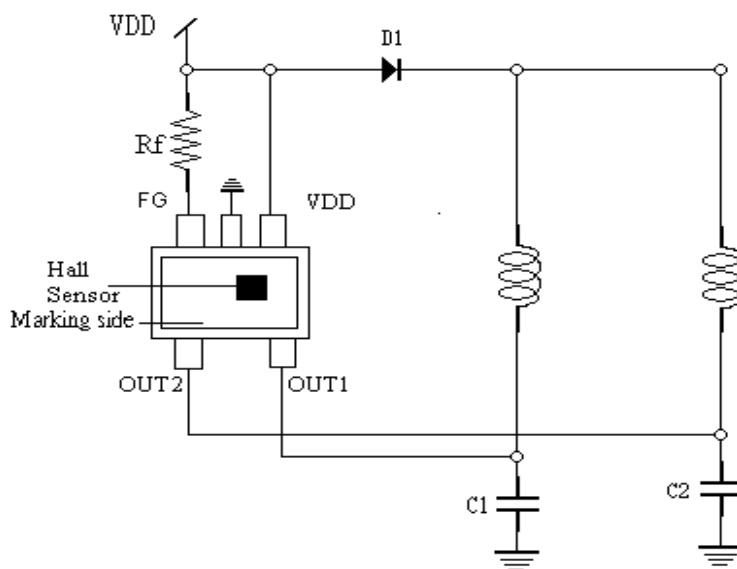

Figure 1.

SIP-4L

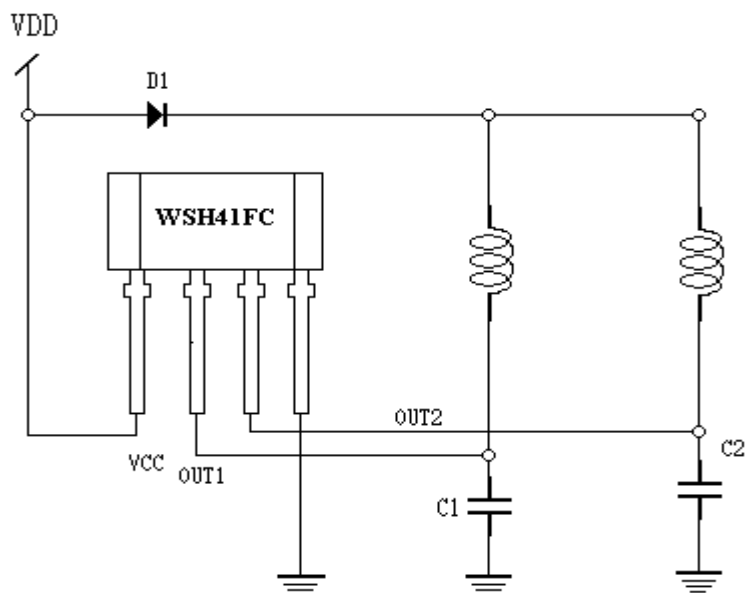

Figure 2.

Winson reserves the right to make changes to improve reliability or manufacturability.