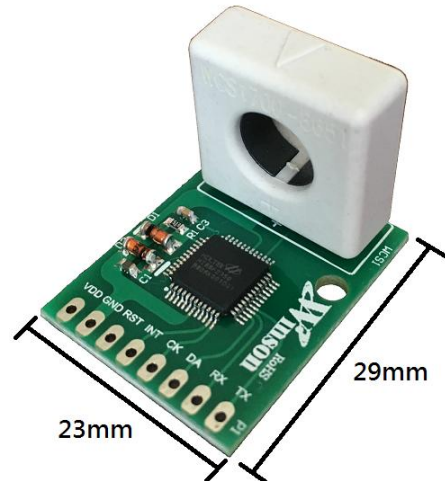

AC / DC Sensing Current Module with Digital Data output**Feature:**

- Accuracy optimization: ultra-high low-current sensitivity with 1% high-current linearity.
- Provides versatile measurement ranges with excellent resolution.
- Diameter 9.0mm conductor through hole
- UART, Baud Rate : 9600 bps, Parity bit : None , Data bit : 8 , Stop bit : 1
- Supply voltage calibration
- Temperature calibration
- Isolation voltage 4KV
- Application note:

<http://www.winson.com.tw/Product/83>

**General Description:**

The Winson Semiconductor WCM1X00 Series delivers high-efficiency, cost-effective AC/DC sensing for industrial and smart power systems. Integrating a high-precision ADC with a 9.0mm through-hole design, it enables non-intrusive installation and 4KV isolation protection without circuit modification.

Its technical core features True RMS (50/60Hz) and DC sensing, with voltage and temperature compensation for stable output. High-precision digital calibration algorithm ensures milliamp-level error at small currents and 1% high-linearity accuracy for large currents.

ABSOLUTE MAXIMUM RATING



Supply Voltage, V_{DD} ----- 6V
 Pass Through Wire Diameter ----- 9.0mm
 Reverse Protection Voltage, V_R ----- -0.3V
 Basic Isolation Voltage ----- 4000V
 Operating Temperature Range, T_A -----
 ----- -40°C to +85°C
 Storage Temperature Range, T_S -----
 ----- -50°C to +125°C

Note:

1.VDD 2.GND 3.RST 4.INT 5.CK 6.DA 7.RX 8.TX **1. Stresses above those listed may cause permanent damage to the devices**

Selection Guide:

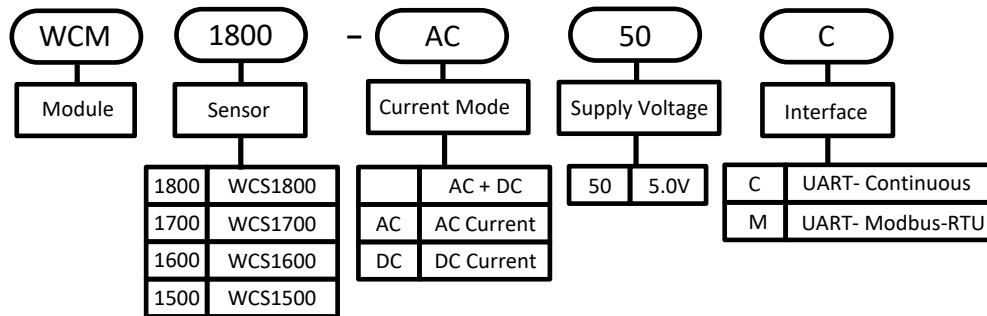

1. The WCM1500 supports “Floating Output” format only. Please refer to the application notes - output format.

2. AC/DC current mode supports continuous transmission only (AC50C, DC50C).

• Measuring Range & Resolution

Model	AC Range	DC Range	Resolution
WCM1800	17A	±25A	18mA
WCM1700	35A	±50A	37mA
WCM1600	50A	±75A	54mA
WCM1500	100A	±150A	110mA

• Communication Format

Suffix Code	Measurement Type	Communication Format
AC50C	AC	Continuous ⁽¹⁾
DC50C	DC	Continuous ⁽¹⁾
50C	AC + DC	Continuous ⁽¹⁾
50M	AC + DC	MODBUS-RTU ⁽²⁾

1. Continuous: UART interface, external reset method (RST pull low to GND).

2. Modbus-RTU: UART interface, TX (Transmitter) / RX (Receiver), internal reset method.

Winson reserves the right to make changes to improve reliability or manufacturability.

Pad Description:

Pad No	Pad Name	I/O	Description
1	VDD	-	The positive power input pin
2	GND	-	The system ground
3	RST	I	The system reset
4	X	-	Reserve
5	X	-	
6	X	-	
7	RX	I	The data of measured current output. Its output is UART communication. The baud rate is 9.6K bits/sec.
8	TX	O	

Electrical Characteristics:
Common Operating Characteristics

Symbol	Parameter	Test Condition	Min.	Typ.	Max.	Unit
V _{DD}	Operation Voltage	-	4.9	5	5.1	V
I _{DD}	Operation Current	-	-	8	10	mA
-	Conductor Through Hole	-	-	9	-	mm
T _{OP}	Operating Temperature	-	-20	-	70	°C

-WCM1800
T_{OP} = 25 °C, V_{DD} = 5.000V

Symbol	Parameter	Test Condition	Min.	Typ.	Max.	Unit
I _{OP}	DC Current Range	-	-25	-	+25	A
	AC Current Range	-	0	-	17	A
I _{RES}	Current Resolution	-	-	18	-	mA
E _{TOT}	Total Output Error	I _{OP} < 5A	-	50	-	mA
		I _{OP} > 5A	-	1	-	%
		Over full range of I _{op} T _{OP} =-20°C to 70°C	-	5	-	%

Winson reserves the right to make changes to improve reliability or manufacturability.



WCM1X00

-WCM1700

$T_{OP} = 25\text{ }^{\circ}\text{C}$, $V_{DD} = 5.000\text{V}$

Symbol	Parameter	Test Condition	Min.	Typ.	Max.	Unit
I_{OP}	DC Current Range	-	-50	-	+50	A
	AC Current Range	-	0	-	35	A
I_{RES}	Current Resolution	-	-	37	-	mA
E_{TOT}	Total Output Error	$I_{OP} < 10\text{A}$	-	100	-	mA
		$I_{OP} > 10\text{A}$	-	1	-	%
		Over full range of I_{op} $T_{OP} = -20\text{ }^{\circ}\text{C}$ to $70\text{ }^{\circ}\text{C}$	-	5	-	%

-WCM1600

$T_{OP} = 25\text{ }^{\circ}\text{C}$, $V_{DD} = 5.000\text{V}$

Symbol	Parameter	Test Condition	Min.	Typ.	Max.	Unit
I_{OP}	DC Current Range	-	-75	-	+75	A
	AC Current Range	-	0	-	50	A
I_{RES}	Current Resolution	-	-	54	-	mA
E_{TOT}	Total Output Error	$I_{OP} < 15\text{A}$	-	150	-	mA
		$I_{OP} > 15\text{A}$	-	1	-	%
		Over full range of I_{op} $T_{OP} = -20\text{ }^{\circ}\text{C}$ to $70\text{ }^{\circ}\text{C}$	-	5	-	%

-WCM1500

$T_{OP} = 25\text{ }^{\circ}\text{C}$, $V_{DD} = 5.000\text{V}$

Symbol	Parameter	Test Condition	Min.	Typ.	Max.	Unit
I_{OP}	DC Current Range	-	-150	-	+150	A
	AC Current Range	-	0	-	100	A
I_{RES}	Current Resolution	-	-	110	-	mA
E_{TOT}	Total Output Error	$I_{OP} < 30\text{A}$	-	300	-	mA
		$I_{OP} > 30\text{A}$	-	1	-	%
		Over full range of I_{op} $T_{OP} = -20\text{ }^{\circ}\text{C}$ to $70\text{ }^{\circ}\text{C}$	-	5	-	%

Winson reserves the right to make changes to improve reliability or manufacturability.

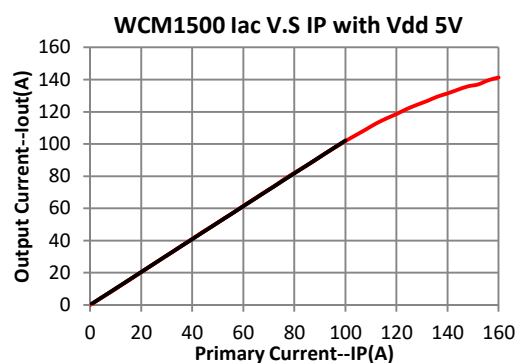
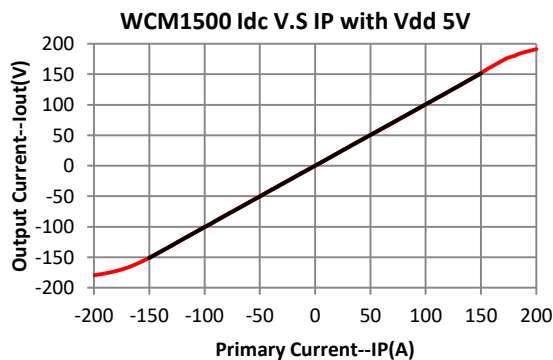
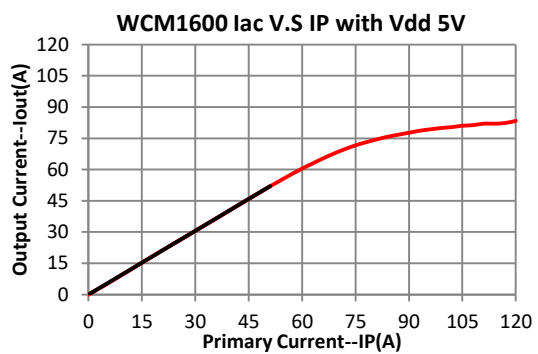
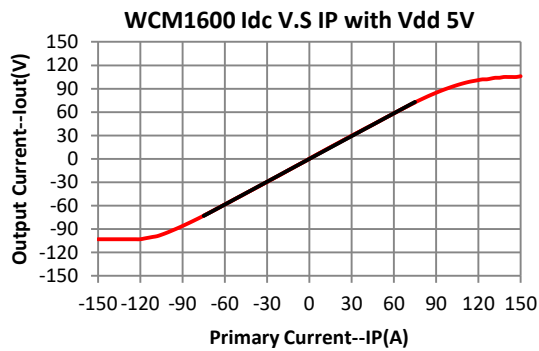
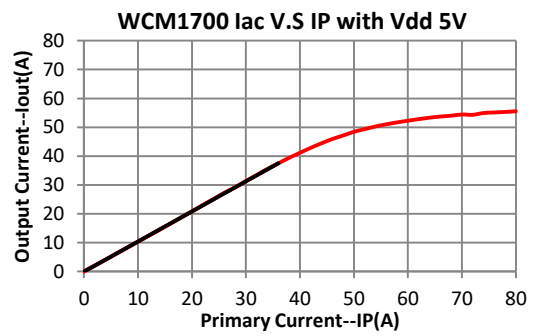
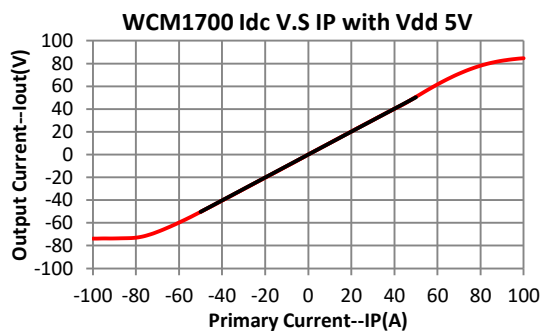
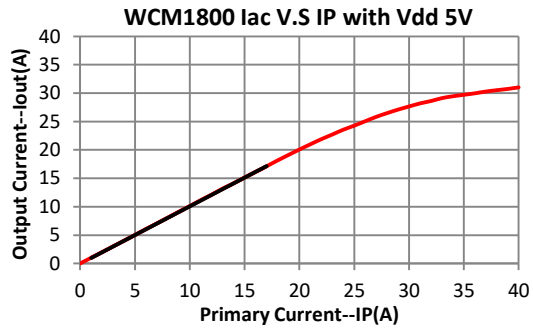
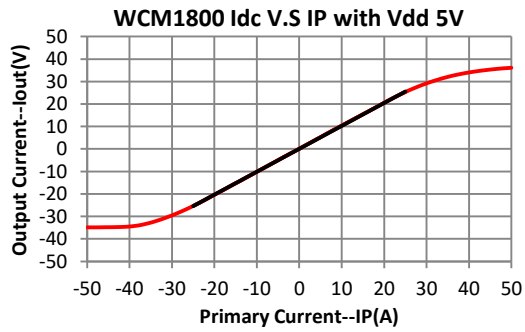

Winson reserves the right to make changes to improve reliability or manufacturability.

Application Note:

Application Diagram:

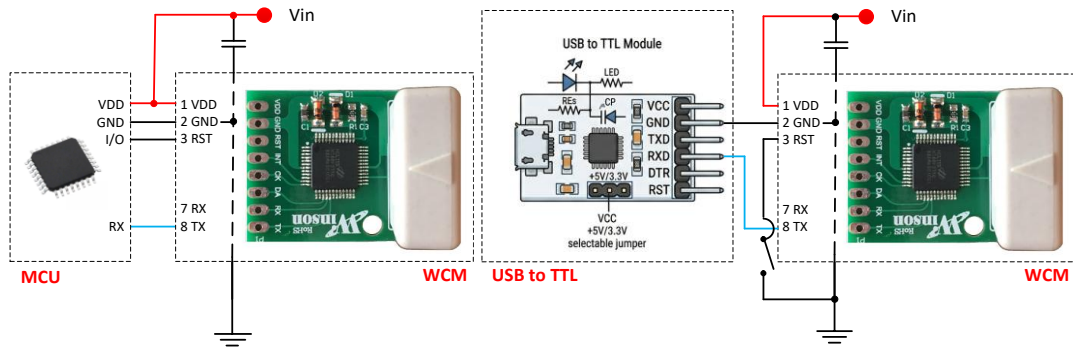

APP. 1. Output UART signal with MCU

APP. 2. Output UART signal with USB to TTL

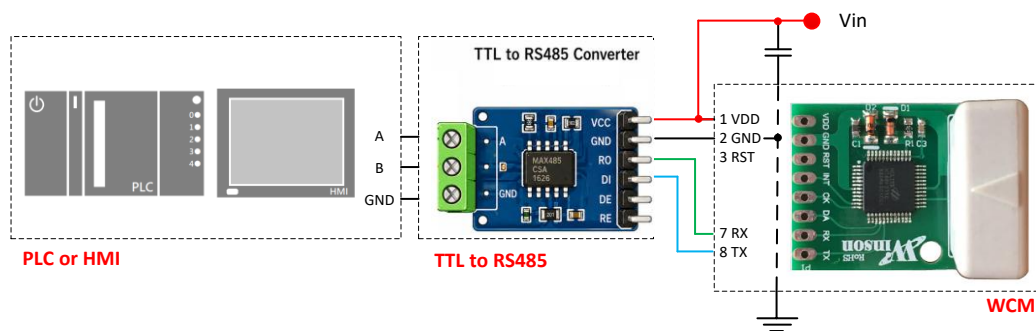

APP. 3. Output UART signal with TTL to RS485

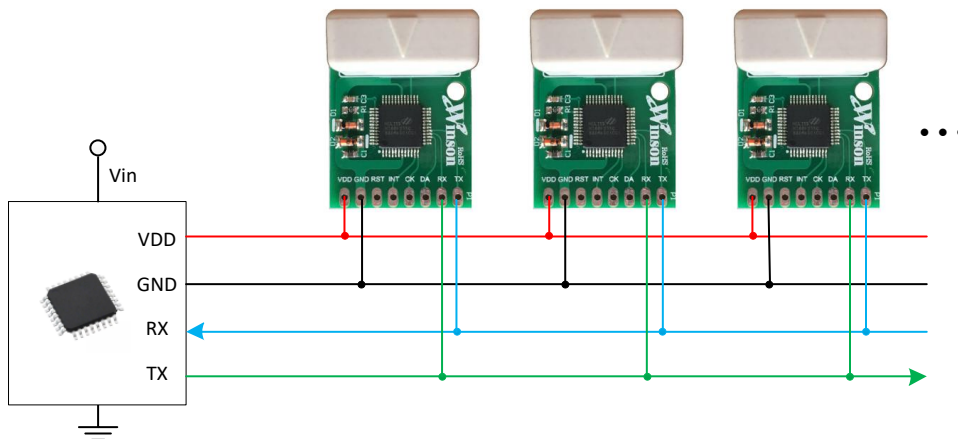

APP. 4. Modbus Connection

Winson reserves the right to make changes to improve reliability or manufacturability.

Output Format**1. Continuous Mode**

For example description, please refer to the "Current Module Application Note":

Measured currents are continuously output via UART (ASCII) in fixed 8-byte frames: **[Sign] [5-digit Value] [CR] [LF]**

• Sign Definition:

~: Alternating Current (AC)

+: Positive Direct Current (DC+)

- : Negative Direct Current (DC-)

• Numerical Format:

Fixed 5-digit integer (excluding decimal point); padded with leading zeros if necessary.

Example: 1.23 A → 01230

Example: 10.76 A → 10760

• Termination Codes:

\r : Carriage Return

\n : Line Feed

• Output Examples :

AC 1.23 A → ~01230\r\n

AC 10.76 A → ~10760\r\n

DC+ 1.23 A → +01230\r\n

DC- 1.23 A → -01230\r\n

2. WCM1500 Output Format (Exceptions)

The WCM1500 outputs fixed 8-byte ASCII frames with an explicit decimal point:

[Sign] [Integer] [.] [Fraction] [CR] [LF]

• Output Examples :

AC 1.23 A → ~1.230\r\n

AC 10.76 A → ~10.76\r\n

DC+ 1.23 A → +1.230\r\n

DC- 100.8 A → -100.8\r\n

Winson reserves the right to make changes to improve reliability or manufacturability.

3. Modbus-RTU Mode

For example description, please refer to the "Current Module Application Note:

Transmission Format (Read & Write)

Slave Address	Function Code	Add. of Registers (High byte first)	No. of Registers (High byte first)	CRC16 (Low byte first)
1 Byte	1 Byte	2 Byte	2 Byte	2 Byte

Receive Format (Read)

Slave Address	Function Code	Byte Count	Data (High byte first)	CRC16 (Low byte first)
1 Byte	1 Byte	1 Byte	N x Byte	2 Byte

Receive Format (Write): Echoes the transmitted data format.

Receive Format: exception

Slave Address	Function Code	Exception Code	CRC16 (Low byte first)
1 Byte	1 Byte	1 Byte	2 Byte

Exceptions set the function code's MSB to 1 (0x80 + Function Code).

• Function Code

03H: Read up to 125 continuous memory words

06H: Write one memory word

• Exception Code

01H: Illegal function code

02H: Illegal data address

03H: Illegal data count

Modbus Parameter List

Item	Address	Byte	R/W	Description
Reset	0x0000	2	Write	Input 256 to Reset
Current	0x0002	4	Read	Hexadecimal signed (HEX), Unit:0.001A Current= HEX / 1000 (A)
Temperature	0x0004	4	Read	Hexadecimal signed (HEX), Unit:0.1°C Temperature= HEX / 10 (°C)
Slave Address	0x0010	2	Write	Default address: 1 Input address1~247
DC / AC	0x0020	2	Write	0: DC / 1: AC

Winson reserves the right to make changes to improve reliability or manufacturability.

True RMS Current Measurement:

In order to calculate true RMS of AC current, you need to know “zero” value of AC current first. The “zero” value of symmetric AC current is the average value $V_o(dc)$ of the current shown in Figure 1.

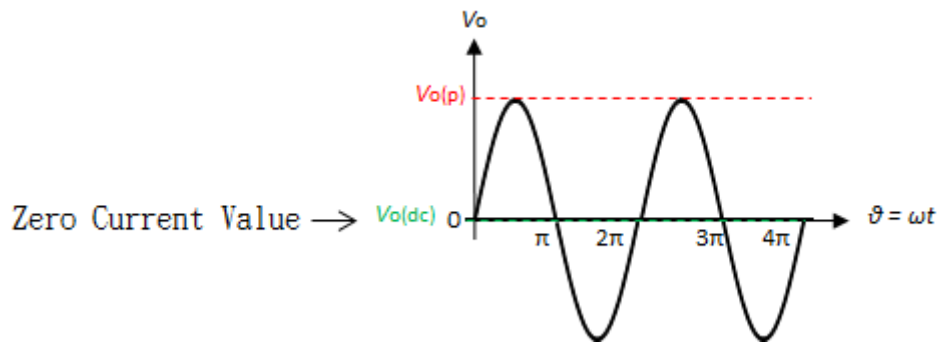

Figure 1 The zero current value of sine waveform

But in asymmetrical AC current, the “zero” value is not the average value $V_o(dc)$ of the current. Based on this “zero” value and do RMS calculation. You will get wrong answer.

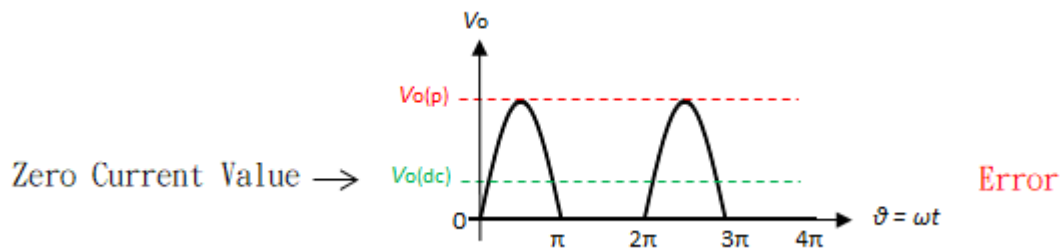

Figure 2 The zero current value of the asymmetric waveform (Error)

The WCM series offer a true RMS solution for both symmetric and asymmetric AC current. It can correctly detect “zero” current value, shown in Figure 3. and do perfect RMS calculation.

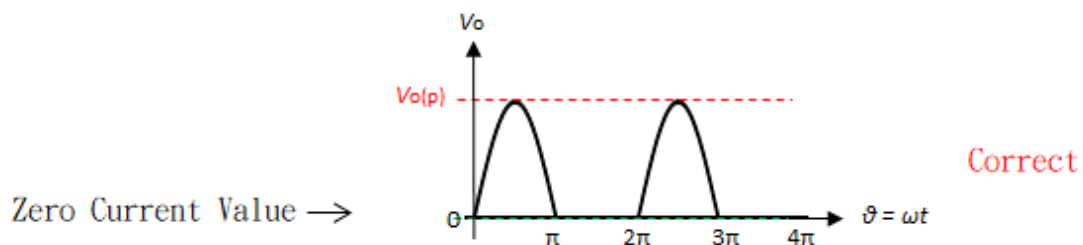
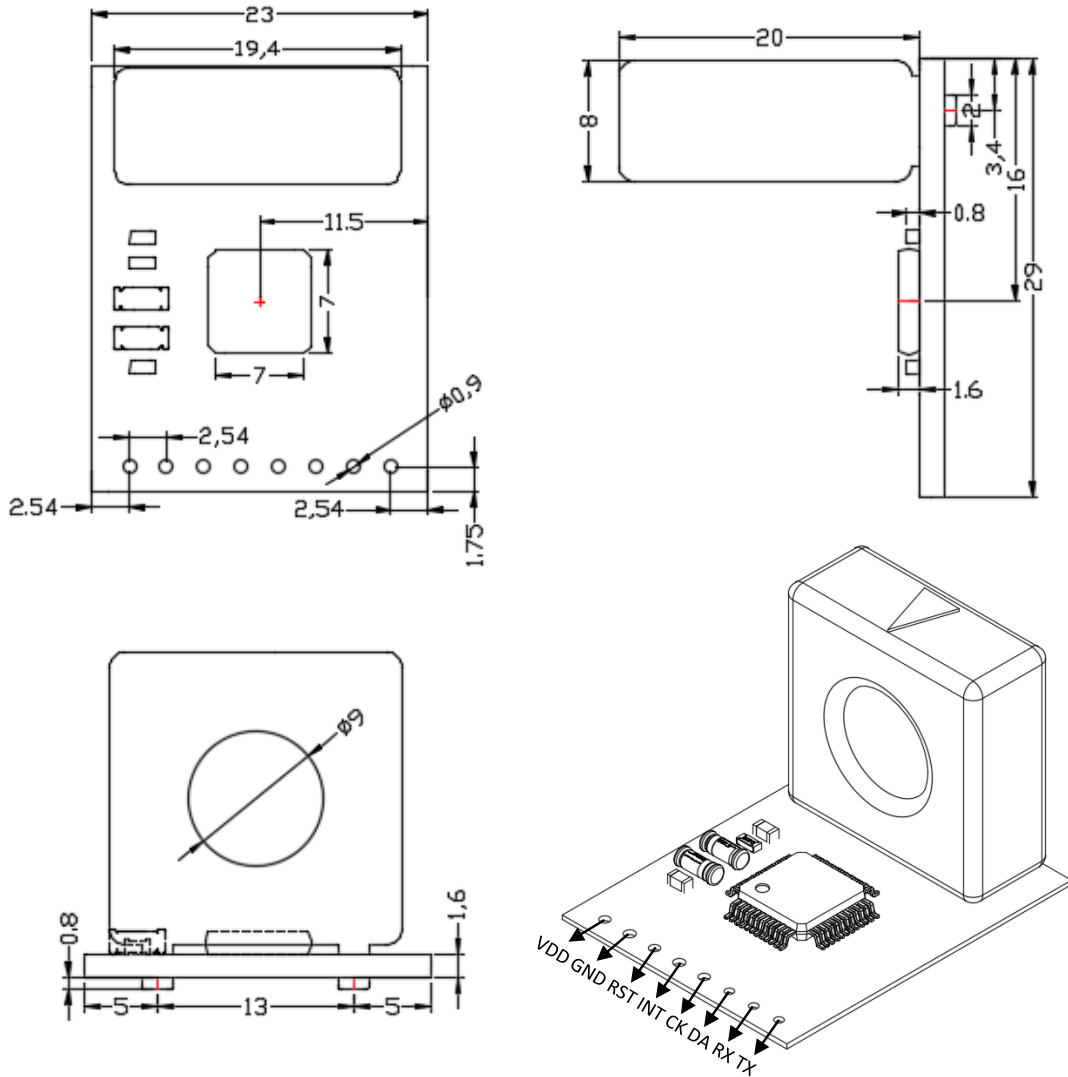

Figure 3 The zero current value of the asymmetric waveform (Correct)

Package:

(Unit: mm)



WCM Application Note : please refer to Winson Website -> Products-> Application Note -> WCM Application Note :
<http://www.winson.com.tw/Product/83>

Winson reserves the right to make changes to improve reliability or manufacturability.