

Unipolar Hall Effect Switch IC

Features

- Operates from 2.4 V to 26 V supply voltage with reverse voltage protection
- Operates with magnetic fields from DC to 15 kHz
- On-chip Hall Sensor
- On-chip temperature compensation circuitry minimizes shifts in on and off points and hysteresis over temperature and supply voltage
- Ideal sensor for speed measurement, revolution counting, positioning, and contactless switches
- On (L) with magnetic **South** pole and Off (H) without magnetic field or with magnetic **North** pole

Functional Description

WSH130NL is designed to integrate Hall sensor with output driver together on the same chip, it is suitable for speed measurement, revolution counting, positioning, and contactless switches. It includes a temperature compensated voltage regulator, a differential amplifier, a Hysteresis controller and a open-collector output driver capable of sinking up to 20 mA current load. An on-chip protection resistor is implemented to prevent reverse power fault.

The temperature-dependent bias increases the supply voltage of the hall plates and adjusts the switching points to the decreasing induction of magnets at higher temperatures. Subsequently, the output can keep switching on/off on more precise switch point regardless to the ambient temperature. WSH130NL are rated for operation over temperature range from -40°C to +125°C and voltage ranges from 2.4 V to 26 V.

Pin Definition

Name	P / I / O	Pin#	Description
Vdd	P	1	Positive Power Supply
Gnd	O	2	Ground
Vout	O	3	Output Pin

Absolute Maximum Rating (at Ta = 25°C)

Supply Voltage	Vcc	-----	26 V
Output breakdown Voltage	Vout _(breakdown)	-----	26 V

Winson reserves the right to make changes to improve reliability or manufacturability.

Magnetic flux density	B	-----	Unlimited
Reverse Protection Voltage	Vr	-----	26 V
Output ON Current (continuous)	Ic	-----	25 mA
Operating Temperature Range	Ta	-----	-40°C to +125°C
Storage Temperature Range	Ts	-----	-65°C to +150°C
Power Dissipation	Pd		
	TO-92S	-----	500 mW
	SOT-23	-----	400 mW

Electrical Characteristics (T = +25 °C, Vcc = 2.4 V to 26V)

Characteristic	Symbol	Test Conditions	Min.	Typ.	Max.	Units
Supply Voltage	Vcc	—	2.4	—	26	V
Output Saturation Voltage	Vout (sat)	Vcc=12V, Ic=10mA, B>Bop	—	0.2	0.6	V
Output Leakage Current	Ileakage	Vcc=12V, B<Brp	—	< 0.1	10	μA
Supply Current	Isupply	Vcc=12V, Output Open	—	2.0	5	mA
Output Rise Time	Tr	Vcc=12V, RL=2kΩ, CL=20pf	—	1.0	10	μs
Output Falling Time	Tf	Vcc=12V, RL=2kΩ, CL=20pf	—	0.3	1.5	μs

Function Block

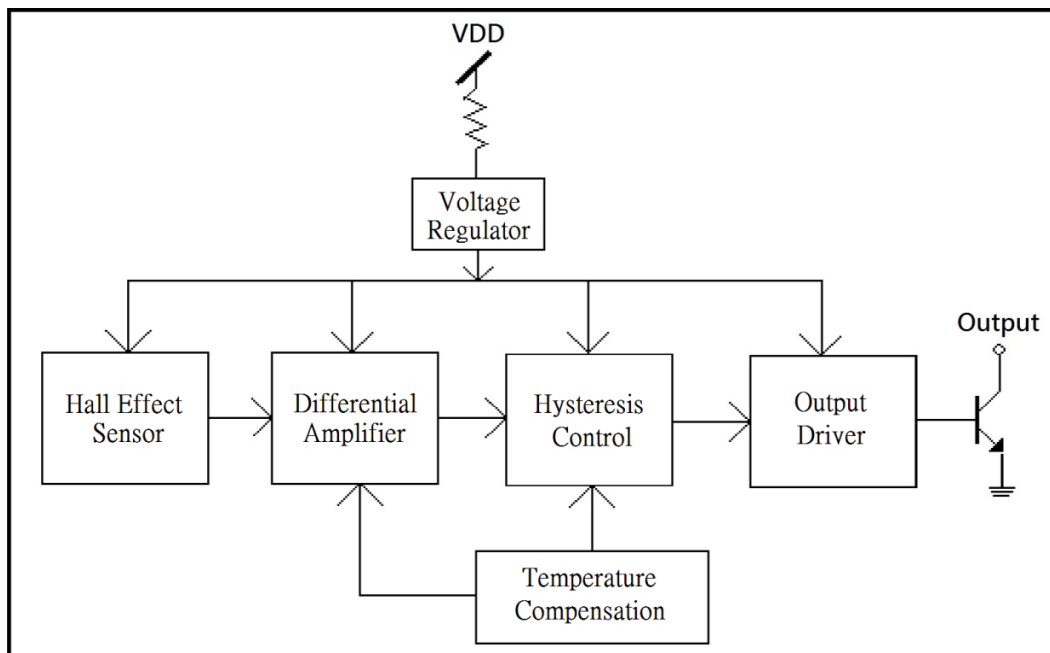

Winson reserves the right to make changes to improve reliability or manufacturability.

Magnetic Characteristics

Characteristic	Symbol	Grade	Min.	Typ.	Max.	Unit
Operating Point	Bop	A			+50	Gauss
		B			+70	Gauss
		C			+150	Gauss
Release Point	Brp	A	+10			Gauss
		B	+10			Gauss
		C	+10			Gauss
Hysteresis Window	Bhys			10	30	Gauss

★ "+" means South magnetic field.

★ 1 mT = 10 Gauss

Ordering Information

WSH130NL-XPAN <input type="checkbox"/> (TO-92) WSH130NL-XPCN <input type="checkbox"/> (SOT23) ↑ Grade Halogen Free	Grade: 1: 50 Gauss 2: 70 Gauss 5: 150 Gauss
---	--

Application Circuit

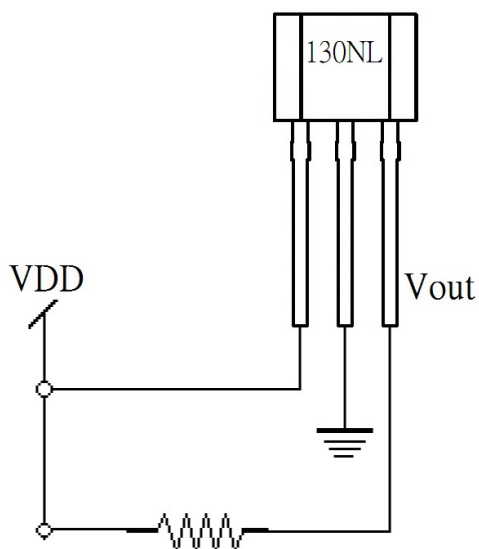

Output vs. Magnetic Field

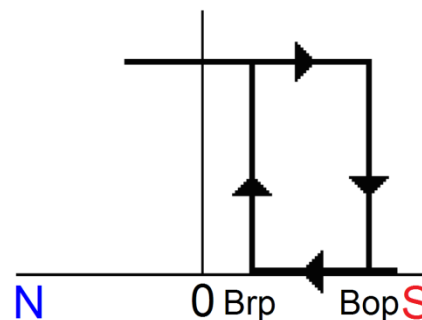

Winson reserves the right to make changes to improve reliability or manufacturability.

Hall Device Sensing Direction

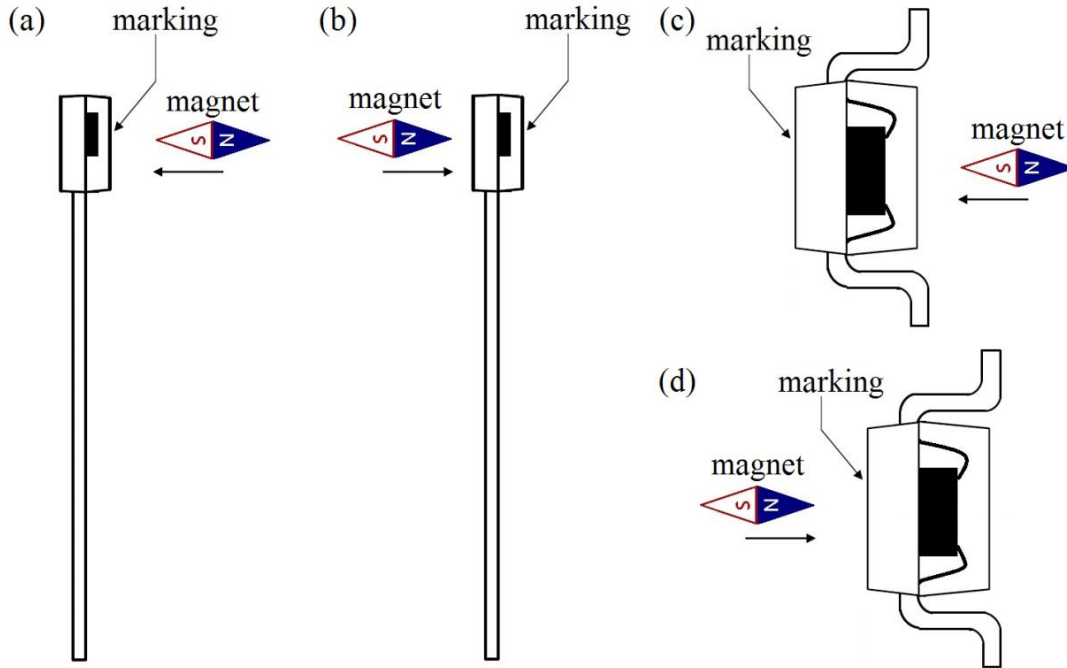

Package Information

《TO-92S》

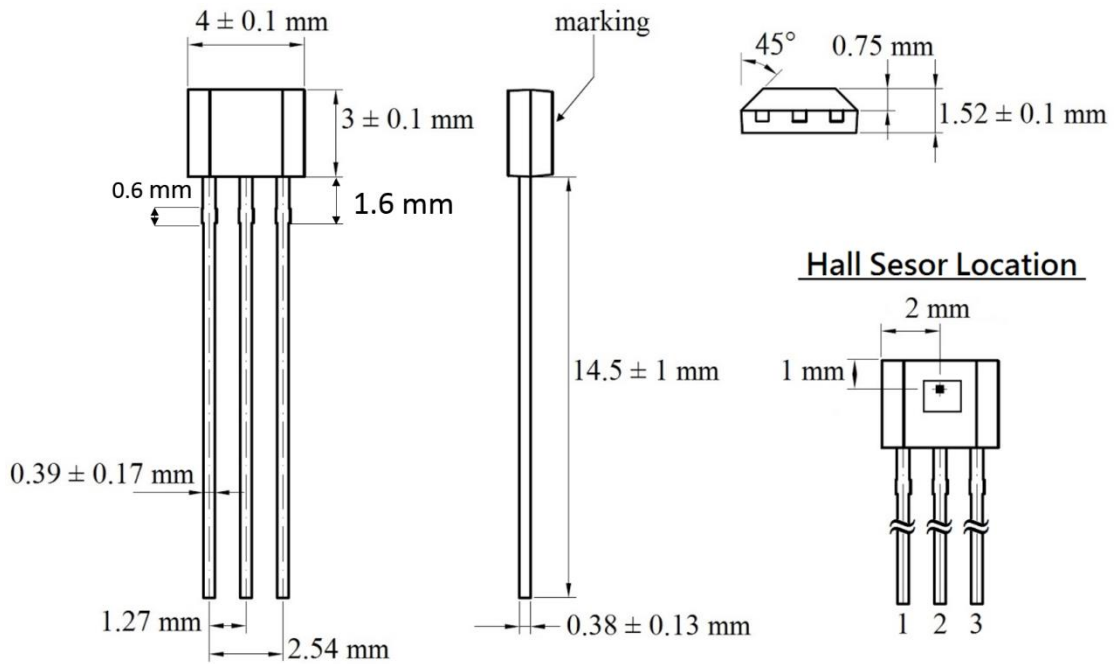

Winson reserves the right to make changes to improve reliability or manufacturability.

《SOT-23》

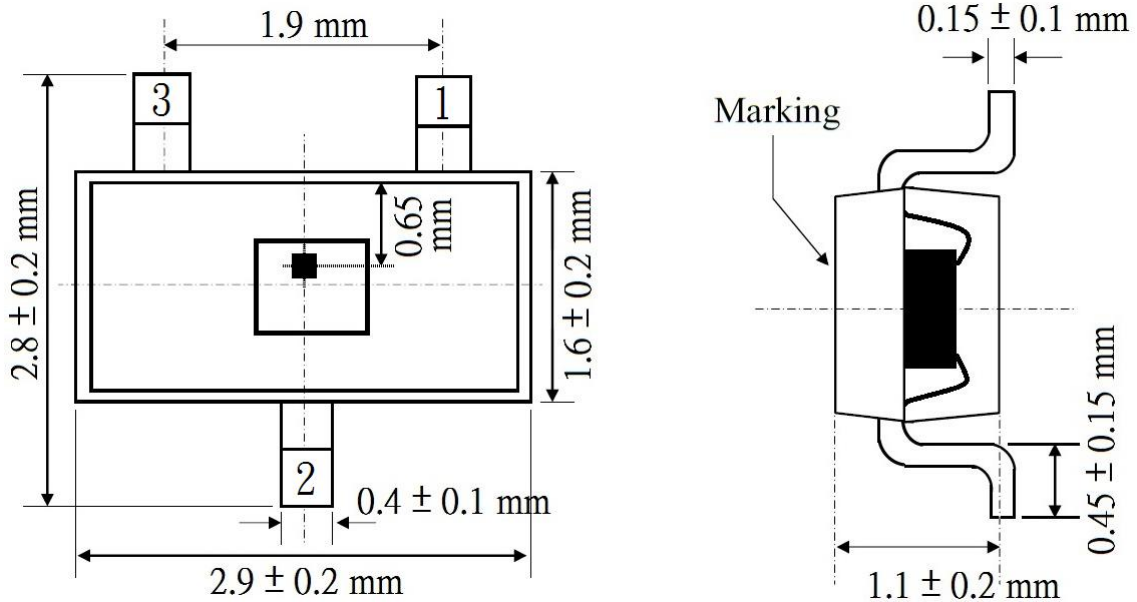

PCB Layout Reference View

SOT-23

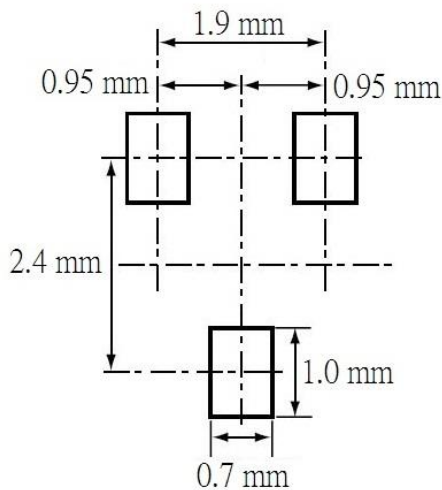

TO-92S

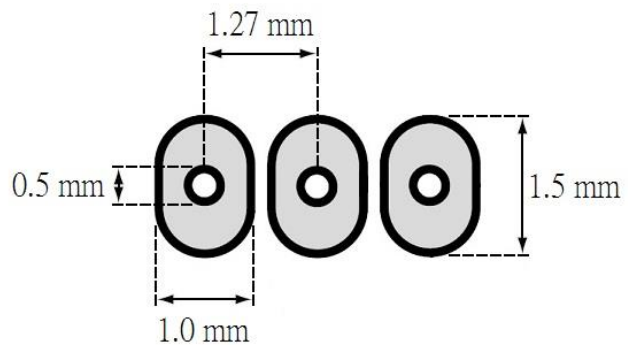

Precautions for the use of Hall Sensor IC: please refer to Winson Website->

Products->Application Note ->Hall Sensor IC Application Note:

<http://www.winson.com.tw/Product/83>

Winson reserves the right to make changes to improve reliability or manufacturability.